

6 COLUMN COMPONENTS



QVF

PROCESS PLANT COMPONENTS



Introduction

QVF column components provide the optimum solution for every requirement encountered in practice for operations such as distillation, rectification, absorption, reaction and extraction because of the wide range of different components available. This applies not only to the various types of column and pipe sections available (plain and jacketed and with or without internals) but also to the wide selection of internals and random and structured packing that can be supplied.

These components are widely used in the chemical, pharmaceutical and allied industries together with other applications such as food and drink production, dye works and electroplating. This is because of the special properties of borosilicate glass 3.3 and PTFE together with the special materials that are used in some instances for internals, plus the fact that borosilicate glass 3.3 is an approved and proven material of construction for pressure vessels.

Reference should also be made in this context to the extreme reliability of the strong and high-duty coupling system used for all components. This is achieved throughout the whole range of nominal sizes by the use of the safety buttress end which has been designed specifically taking into account the properties of the material, coupled with a reliable flange system.

The complete range of standard column components is described on the following pages. Non-standard components can also be supplied to special order. Column sections and fittings in other materials (glass-lined steel etc.) can also be supplied on request.

A detailed listing of all column components by »Description« and »Catalogue Reference« can be found in the »Index«.



Detailed information on a number of the topics referred to in the following pages can be found in Section 1 »Technical Information«.

Further information on complete columns can be found in our special leaflets dealing with individual unit operations.

Details of the design of the different types of optimised buttress ends are illustrated alongside.



DN15 - DN150



DN200 - DN300



DN450 - DN1000

GMP compliant installations

The use of columns and the layout of interconnecting pipeline incorporating valves when designing plant and equipment complying with GMP regulations, calls for special care in both the planning and selection of the components together with the materials of construction used for them. Borosilicate glass 3.3 has a number of special properties that are highly valued in the pharmaceutical industry and these in conjunction with materials approved in accordance with the FDA catalogue such as glass-lined steel (special versions of large bore column bottom sections), PTFE (redistributors and packing retainers) and special materials (e.g. internals) ensure that any build-up of unwanted deposits is avoided in areas which come in contact with the product. A design without any dead space, which ensures that components drain fully and can be cleaned easily and effectively, is achieved by the shape of the components, the way they are installed and the selection of suitable valves. Where the external surfaces of complete assemblies have to comply with clean room requirements, appropriate stainless steel coupling and support material can be supplied (please see Section 9 »Couplings« and Section 10 »Structures and Supports«).

We would be happy to advise you on the basis of the regulatory requirements applicable to a particular case and the guidelines drawn up by us for the design of GMP compliant plant.

Coated column components

Damage to borosilicate glass 3.3 plant resulting from accidental external causes cannot be entirely excluded. This is primarily due to the relatively rigorous conditions prevalent in production plants and applies especially where no additional protection is provided in the form of insulation.

Our answer to this problem is to provide borosilicate glass 3.3 column components with a Sectrans transparent coating. This can be applied irrespective of the shape of the component and it provides additional protection without having any adverse effect on visual monitoring of the process.

A glass fibre reinforced polyester coating providing a higher level of protection can also be supplied on request. This does have a slightly adverse effect on the transparency of the glass, making it translucent and not transparent.

Permissible operating conditions

While the maximum permissible operating temperature for all borosilicate glass 3.3 column components is generally 200 °C ($\Delta\theta$ 180 K, the maximum permissible operating pressure is governed by the main nominal size of the component but not by its shape. Detailed information on this and the operation of jacketed components can be found in Section 1 »Technical Information«.

The permissible operating conditions for components in other materials can be found in the respective product description.



Glass components suitable for higher permissible operating conditions can be supplied on request.

COLUMN SECTIONS

Depending on the nominal size, column sections are supplied in 1000 and/or 1500 mm lengths, and also with or without a thermometer branch. They have an integral shelf on which the packing support rests. A PTFE ring is fitted between the support shelf and packing support to prevent direct contact between the two parts.

Column sections can be filled with random packing or alternatively structured packing if the free cross sectional area of the packing support is large enough (please see page 6.5), For structured packing higher free cross sectional areas can be achieved by the use of »CSDU.« type column sections (please see page 6.12).

Higher free cross-sectional areas can be achieved in the DN 80 to DN 300 nominal size range by combining pipe sections (please see section 2 »Pipeline Components«) with »LBE.« type packing supports (please see page 6.8). Use of pipe sections and special types of support plates is possible across the whole range of nominal sizes. For larger diameters, the patented support CORE-TRAY is available, which also serves as fluid collector and distributor. Column sections with structured packing, such as DURAPACK® high performance borosilicat glass 3.3 packing, described on page 6.12 are an example of this type of application.

Pipe sections can also be used to extend the length of column sections i.e. to increase the packed height, provided the permissible load-bearing capacity of the packing support is not exceeded.

Column sections suitable for installing distribution plates as well as packing retainers are described on pages 6.6 and 6.10. Precision bore pipe sections with and without buttress ends for special internals or chromatography columns can be found on page 6.32.

Jacketed column sections can also be supplied on request.



All column sections are supplied complete with a packing support. Random packing (please see page 6.9) and structured packing (please see page 6.10 and 6.11), should be ordered separately.

Details of free cross-sections (including packing support), the load-bearing capacity of the support rings in conjunction with the supplied packing supports and the recommended packing can be found in the table on the following page. The free cross-section of individual components used to construct columns and the load-bearing capacity of the packing supports is indicated in the description of the product in question.

The minimum size of random packed or stacked raschig rings can also be found in the table on the following page. Where raschig rings of smaller sizes are used a layer of high performance DURAPACK® should be installed first.

In the table below »DN« refers to the nominal size of the column.

For manufacturing reasons on column sections in DN 800 and DN 1000 nominal sizes in which the support shelf also acts as a redistributor the thermometer branch can only be located below the upper buttress end.

COLUMN SECTIONS

DN	DN1	L	L1	L2	H	Free cross-section (%)	Type	Load bearing capacity (N)	Minimum size of packing (FC)		Cat. Reference without thermo-meter branch	Cat. Reference with thermo-meter branch
									random packed,	stacked		
80	25	1000	108	91	835	32	A	230	FC8	-	CS80/1000	CST80/1000
100	25	1000	122	96	840	36	A	350	FC10	-	CS100/1000	CST100/1000
150	25	1000	147	111	830	34	A	700	FC15	FC20	CS150/1000	CST150/1000
200	25	1000	171	111	830	45	B	900	FC20	FC20	CS200/1000	CST200/1000
200	25	1500	171	111	1330	45	B	900	FC20	FC20	CS200/1500	CST200/1500
300	25	1000	221	111	825	56	B	1000	FC25	FC30	CS300/1000	CST300/1000
300	25	1500	221	111	1325	56	B	1000	FC25	FC30	CS300/1500	CST300/1500
450	25	1500	299	151	1234	44	B	3050	FC50	FC50	CSN450/1500	CSTN450/1500
600	25	1500	377	151	1209	53	B	3950	FC50	FC50	CSN600/1500	CSTN600/1500
800	40	1500	562	248	1105	55	C	10500	FC50	FC50	CSN800/1500	CSTN800/1500
1000	40	1500	650	250	1081	56	C	12500	FC50	FC50	CSN1000/1500	CSTN1000/1500

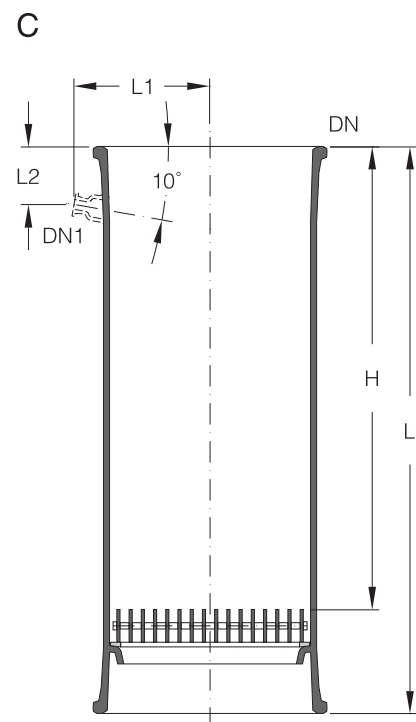
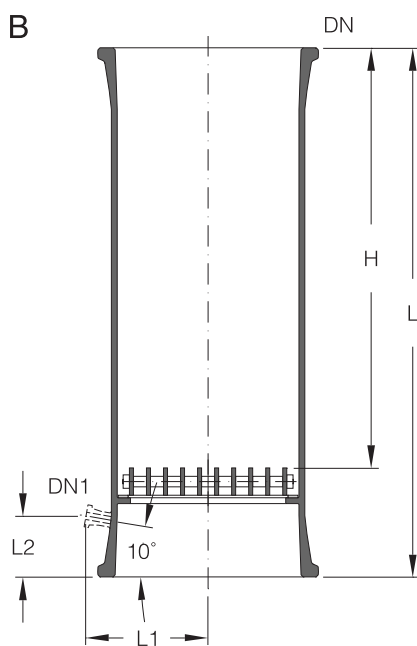
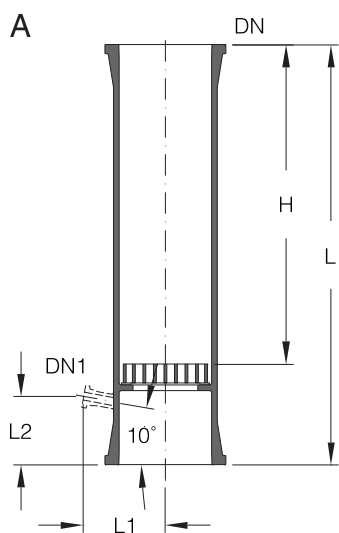

COLUMN COMPONENTS

COLUMN SECTIONS FOR LIQUID DISTRIBUTION TRAYS

Irrespective of the nominal size these column sections are supplied in one length only so that they still provide sufficient height for random or structured packing. They have three extra side branches offset at 120° from each other so that a nozzle type distributor can be fitted to redistribute the liquid. These are located at an appropriate height so that a PTFE redistributor (please see page 6.16) can be installed in the coupling above the distribution plate.

These column sections can be supplied with or without thermometer branch.



All column sections are supplied complete with packing support. Distribution trays, random packing (please see page 6.9) and structured packing (please see page 6.11) should be ordered separately.

Further technical information and dimensions can be found on page 6.5, where »CS..« and »CST..« type column sections are described.

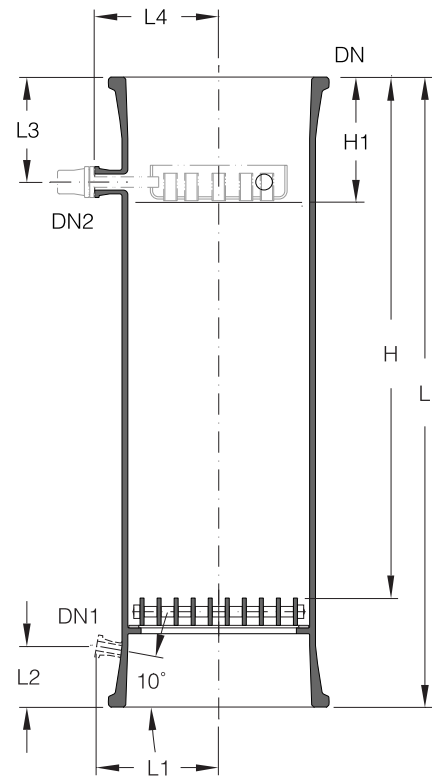

DN	DN1	DN2	L	H	H1	L1	L2	L3	L4	Reference without thermo- meter branch	Reference with thermo- meter branch
200	25	25	1500	1330	150	171	111	110	165		CSVT200/1500
300	25	25	1500	1325	165	221	111	125	218	CSV200/1500	CSVT300/1500
450	25	40	1500	1234	205	299	151	135	300	CSV300/1500	CSVTN450/1500
600	25	40	1500	1209	255	377	151	175	380	CSVN450/1500 CSVN600/1500	CSVTN600/1500

PACKING SUPPORTS FOR RANDOM PACKED COLUMN SECTIONS

For nominal sizes up to DN 300 we supply »LB.« borosilicate glass 3.3 packing supports for the column sections described on pages 6.5 and 6.6. For larger diameters we provide type »HD.« packing supports for which a combination of glass and PTFE is used.

As packing supports are always supplied as part of the column section assembly, they are normally only ordered separately when required as replacements. The PTFE ring on which they are seated is supplied complete with the support.

Details concerning free cross-sections of the supports and their load-bearing capacities when loaded evenly and on the minimum size of packing to be used are given on page 6.5.



Packing supports for structured packing can be found on page 6.16.

In the table below »DN« refers to the nominal size of the column.

DN	L	D	E	Type	Reference
80	21	70	7	A	LB80
100	21	95	7	A	LB100
150	31	140	13	A	LB150
200	31	190	17	A	LB200
300	31	270	22	A	LB300
450	66	440	33	B	HD450
600	91	590	33	B	HD600
800	133	790	39	B	HD800
1000	153	968	39	B	HD1000

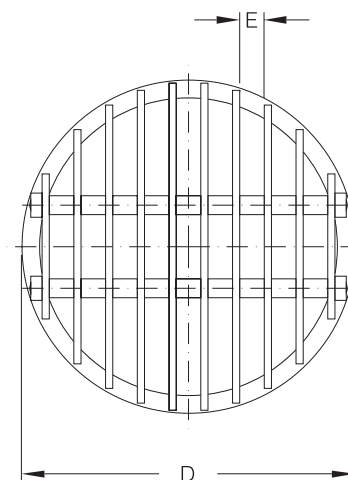
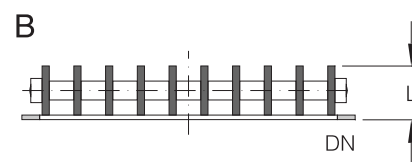
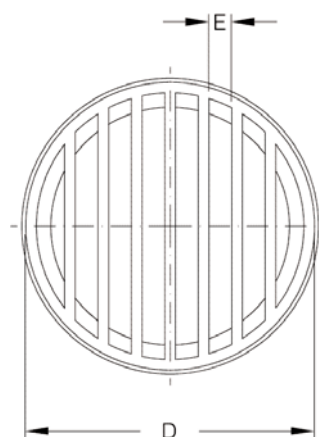
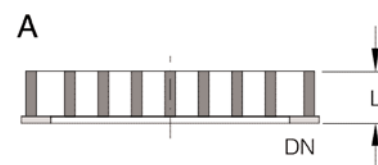

COLUMN COMPONENTS

PACKING SUPPORTS FOR RANDOM PACKED PIPE SECTIONS

These items are used with pipe sections (please see section 2 »Pipeline Components«). This alternative provides larger free cross-sections than the combination of column sections with packing supports. In addition to the glass support plate the supply also includes the special backing flange with special insert, screwed rods, nuts and compression springs.

Details concerning free cross-sections of the supports and their load-bearing capacities when loaded evenly can be found in the table below.

DN	L	Free cross-section (%)	E	Load bearing capacity (N)	Minimum size of packing (FC)		Type	Reference
					random packed	stacked		
80	25	56	7	700	FC 8	-	A	LBE80
100	25	72	7	900	FC10	-	A	LBE100
150	50	77	13	1000	FC15	FC20	A	LBE150
200	50	81	18	1100	FC20	FC20	B	LBE200
300	50	81	21	1200	FC25	FC30	B	LBE300

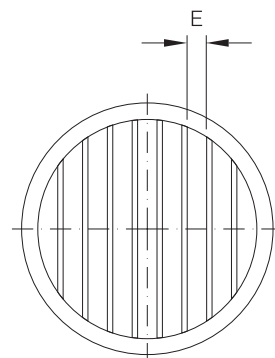
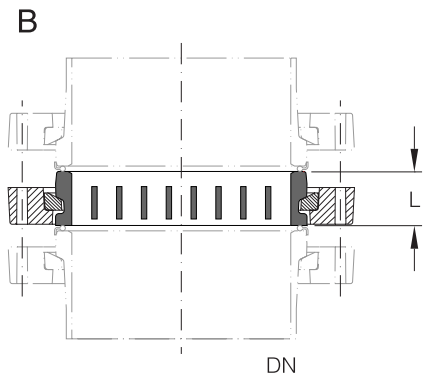
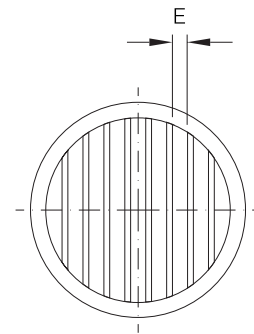
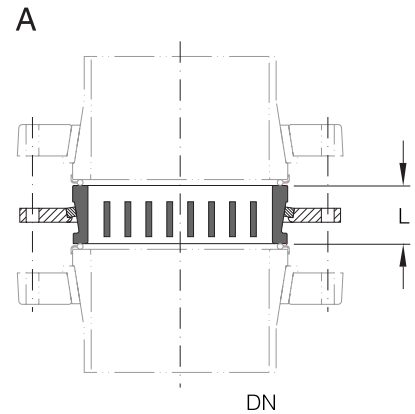

COLUMN PACKING

In addition to the borosilicate glass 3.3 raschig rings shown here, we can also supply other column packing in materials and geometries to suit the individual application. We would be happy to assist you in the selection of suitable packing and the design of the columns.

Borosilicate glass 3.3 structured packing (DURAPACK®) can be found on pages 6.11.

Column sections with bubble-cap plates are shown on page 6.30 onwards.



The permissible height of the packing is restricted by the load-bearing capacity of the packing support fitted in the column section (please see page 6.5).

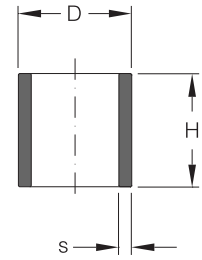

D x H	s	Bulk density random (kg/m ³)		Surface random (m ² /m ³)		Free volume random (%)		Reference
		packed	stacked	packed	stacked	packed	stacked	
8 x 8	1,0	660	-	633	-	69	-	FC8
10 x 10	1,0	520	-	487	-	75	-	FC10
15 x 15	1,2	435	-	331	-	79	-	FC15
20 x 20	1,2	345	-	259	-	83	-	FC20
25 x 25	1,4	290	-	186	-	86	-	FC25
30 x 30	1,4	275	325	173	205	86	84	FC30
38 x 38	2,0	300	360	135	162	85	83	FC40
50 x 50	2,5	260	335	93	120	87	84	FC50

COLUMN COMPONENTS

PACKING RETAINERS

These components are installed above packed column sections to prevent damage to reflux separators or condensers by the carry-over of column packing. They are in the form of a PTFE ring of selected quality with a tantalum wire mesh.

Packing retainers are installed in the same way as gaskets between two buttress ends and therefore no additional gasket is required.

 Packing retainers should not be used in place of packing supports (please see page 6.7).

DN	L	E	Free cross-section (%)	Reference
80	5	10	65	CPC80
100	5	10	85	CPC100
150	6	10	90	CPC150
200	6	18	80	CPC200
300	4	20	85	CPC300
450	4	20	85	CPCN450
600	5	30	95	CPCN600
800	7	30	95	CPC800
1000	7	37	90	CPC1000

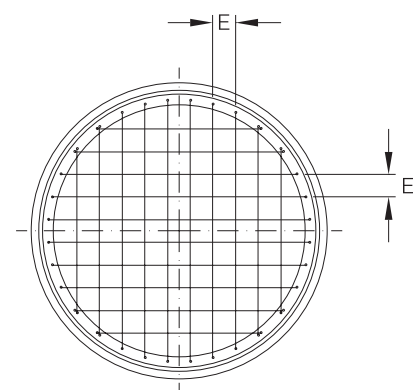
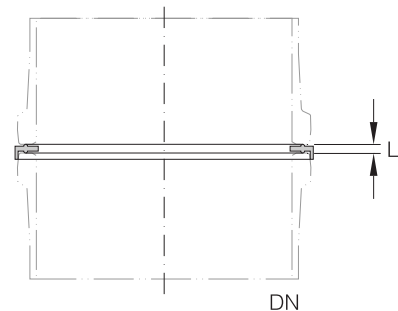

STRUCTURED PACKING

Mass transfer in absorption, desorption, rectification and extraction columns can be improved by the use of structured packing in various materials. They provide high throughput coupled with low pressure drop and at the same time ensure good separation efficiency.

The DURAPACK® borosilicate glass 3.3 mass transfer packing referred to here combines these benefits with the ability to handle very corrosive and/or high purity products. Further information such as areas of application, pressure drop, separation efficiency and flooding point can be found in our special brochure "DURAPACK® Borosilicate Glass 3.3 Structured Mass Transfer Packing".

 Complete couplings with longer bolts are required for column sections with structured packing installed, this is because of the support rings and packing restraints clamped between the flat buttress ends. These can be found in the section 9 »Couplings«.

We would be happy to provide advice on process engineering design aspects and the selection of suitable components for your particular application.

STRUCTURED PACKING

DURAPACK®-Elements

The individual corrugated glass plates are homogeneously fused together to form flow channels inclined at an angle of 45° to each other. The specific surface area is 300 m²/m³. Further information about pressure drop, separation efficiency and flooding throughput can be found in our special brochure (please see page 6.10).

In the DN 100 to DN 450 range of nominal sizes, the packing elements are one-piece. In the larger sizes they are segmented. They can be used in column sections and pipe sections (please see section 2 »Pipeline Components«) and they are installed using special edge seals which are included in the supply (two seals up to DN 300 and one above DN 300 size).

The one-piece packing is supported on a PTFE support ring (steel reinforced in DN 450 and above) and the segmented packing is supported on a combination of support ring and packing support (please see pages 6.13 and 6.16). The support rings are clamped between the buttress ends and also serve as gaskets.

For larger diameters, the patented support CORE-TRAY is available, which also serves as fluid collector and distributor.



On request we can also supply DURAPACK® elements in different sizes or for larger diameters (e.g. glass-lined columns) as well as structured packing in other materials of construction.

The installation of DURAPACK® mass transfer packing calls for considerable experience and requires a certain amount of fitting work (make-up rings, retainers, drilling of holes for measurement probes). Any elements supplied including accessories should, therefore, only be installed by our trained installation personnel on the actual site. The maximum packing height should not exceed 3 metres.

Where the packing elements are not intended for use in glass pipes, please consult us because of the possibility of varying diameters and the possible need for adaptation of the edge seal.

In the tables below »DN« refers to the nominal size of the pipe in which the packing is installed.

DN	D	H	Weight of one layer (kg)	Number of segments in a layer	Reference
100	90	200	0,5	1	DUPA100/300
150	140	200	1,3	1	DUPA150/300
200	190	200	2,3	1	DUPA200/300
300	285	200	5,2	1	DUPA300/300
450	435	200	12,1	1	DUPA450/300
600	585	200	22,4	4	DUPA600/300
800	798	200	40,2	4	DUPA800/300
1000	973	200	60,0	7	DUPA1000/300

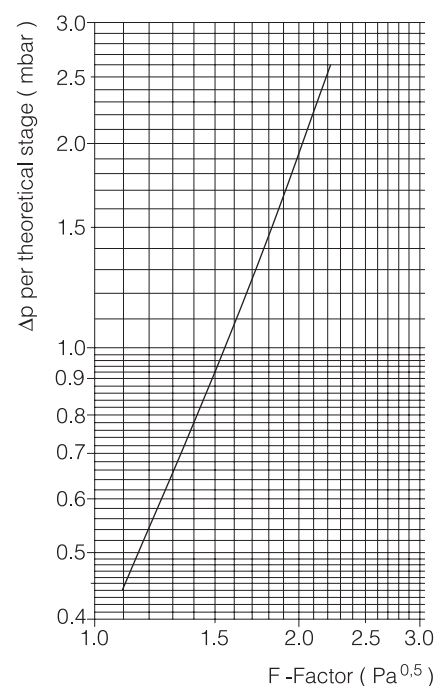
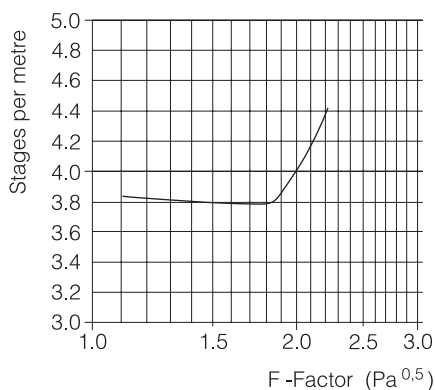
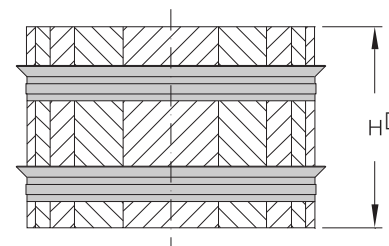
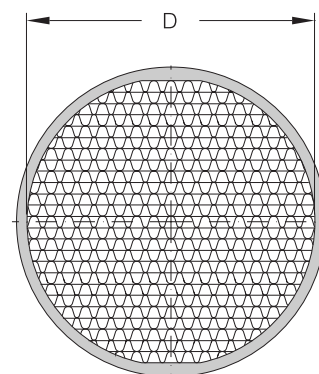

COLUMN COMPONENTS

COLUMN SECTIONS FOR STRUCTURED PACKING

In the DN 100 to DN 1000 nominal bore range special column sections with thermometer branch can be supplied for structured packing such as the high efficiency DURAPACK® packing described on page 6.11. Compared with the »CS..« type (see page 6.5) they provide a significantly larger free cross sectional area and are, therefore, more suitable for internals of the type mentioned.

To ensure that the structured packing is installed properly in these column sections we supply not only special support grids and rings (see page 6.16 and 6.13) but also other required elements such as restrainers and spacer rings (see page 6.15).



To connect column sections containing structured packing to each other and to other glass components »CPDU..« or »CCSFDU..« couplings (see section 9 »Couplings«) with longer bolts are required because of the additional items such as support rings and restrainers clamped between the buttress ends.

The end form, which depends on the nominal size is shown in the diagram on page 6.2. Further information can be found in section 1 »Technical Information«.

DN	DN1	L	L1	L2	Reference
100	25	1000	295	122	CSDU100
150	25	1000	295	147	CSDU150
200	25	1000	295	171	CSDU200
300	25	1000	290	221	CSDU300
450	25	1000	230	299	CSDU450
600	25	1000	230	377	CSDU600
800	40	1000	215	562	CSDU800
1000	40	1000	215	650	CSDU1000

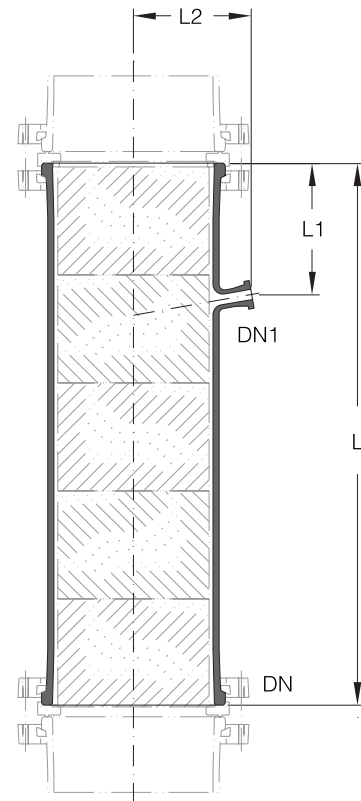

SUPPORT RINGS FOR STRUCTURED PACKING

Support rings are generally used to support structured packing such as high performance DURAPACK® packing (please see pages 6.10 and 6.11) in pipe sections. Up to DN 300 nominal size they are made of selected quality PTFE. In larger nominal sizes PTFE-sheathed steel rings are used. These also act as a support flange for the column section. In the DN 800 and DN 1000 nominal sizes there is also the alternative possibility to combine the support ring with a fixed-point flange with the latter supported on a steel angle substructure. Further information to this can be found in section 10 »Structures and Supports«.

Support rings are clamped between the buttress end faces using longer bolts in the coupling. The rings have a bead on both faces, so that no additional gasket is required.



The permissible loads for support rings and the packed heights applicable to structured packing indicated in the following tables should not be exceeded.

Above an operating temperature of 150 °C and with packed heights of more than one metre, PTFE-sheathed steel rings (please see page 6.14) must also be used in the DN 100 to DN 300 nominal size range.

Where segmented packing is used (e.g. with DURAPACK® in the DN 600 to DN 1000 nominal size range) »SPP.« packing supports (please see page 6.16) should also be used in addition to the support rings.

PTFE (DN 100 to DN 300) or steel/PTFE (DN 800 and DN 1000) support rings are also used as packing restrainers (please see page 6.15).

SUPPORT RINGS FOR STRUCTURED PACKING

PTFE Support Rings

DN	D	L	packed height	Load bearing capacity (N)	Free cross-section (%)	Reference
100	80	12	1m DUPA	35	64	SPS100
150	130	14	1m DUPA	78	75	SPS150
200	180	15	1m DUPA	140	81	SPS200
300	275	20	1m DUPA	315	84	SPS300

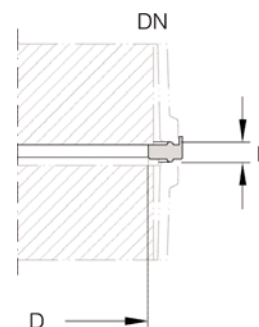

COLUMN COMPONENTS

SUPPORT RINGS FOR STRUCTURED PACKING

Steel/PTFE Support Rings

DN	D	K	K1	L	n x d1	n x d2	packed height	Load bearing capacity (N)	Free cross-section (%)	Type	To suit to support frame	Reference
100	80	178	254	18	6 x M8	3 x 11	3m DUPA	105	64	A	RRD150 a. 150/1.25	SPSH100
150	130	254	295	20	6 x M10	3 x 11	3m DUPA	235	75	A	RRD200	SPSH150
200	180	295	400	22	8 x M8	3 x 11	3m DUPA	415	81	A	RRD300	SPSH200
300	275	400	495	22	12 x M8	3 x 14	3m DUPA	935	84	A	RRDN400 a. 400/2	SPSH300
450	380	585	710	27	16 x M8	3 x M12	3m DUPA	2100	71	B	RRDN600 a. 600/2.5	SPSH450
600	520	710	850	33	20 x M12	3 x M16	2m DUPA	2490	75	C	U-Profile-Frame	SPSH600
800	725	950	-	25	24 x 14	-	2m DUPA	4425	82	D	-	SPSH800
1000	910	1120	-	25	28 x 14	-	2m DUPA	6915	83	D	-	SPSH1000

A

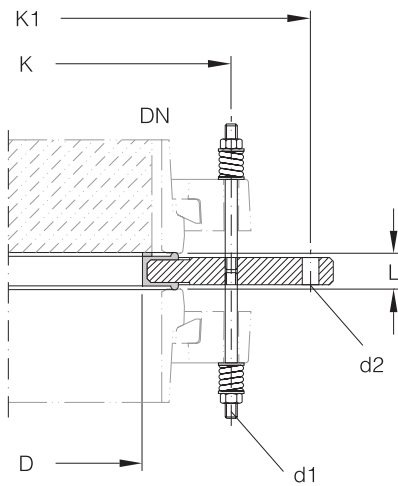

B

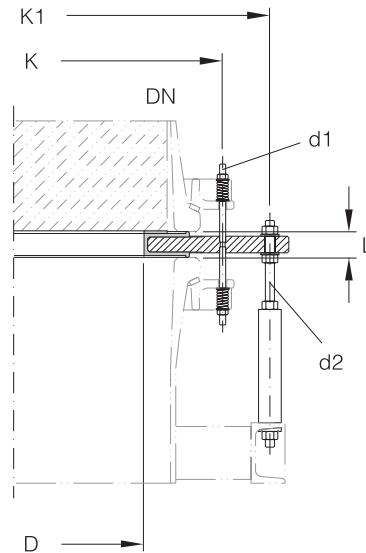

C

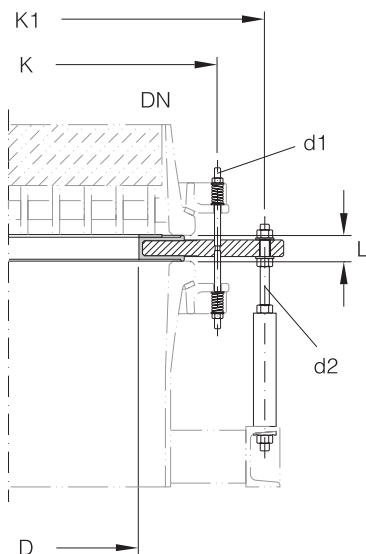

D

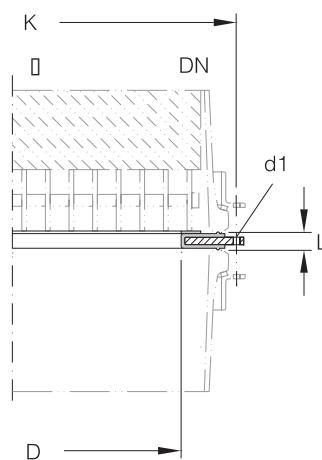

SPACER RINGS FOR STRUCTURED PACKING

Structured packing such as high efficiency DURAPACK® packing (please see page 6.11) must always be very carefully fixed after installation in column sections. Otherwise there is the risk of relative movement between the jacket and the internals should any pressure surges occur which could result in damage to the packing elements with consequent loss of performance or even disruption of operation.

For this reason, one or more spacer rings should be inserted above a section of structured packing to fill any free space between the internals and a restrainer (please see below) clamped between the buttress ends in the upper coupling. These spacer rings are made of selected quality PTFE.

It is advisable to have a variety of rings available in different thicknesses to ensure that the free space can be filled to optimum effect.

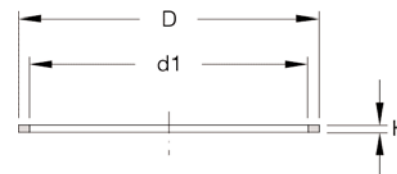

 In the table below »DN« refers to the nominal size of the column.

DN	D	d1	H	Free cross-section %	Reference
100	96	80	2	64	SPC100/2
100	96	80	5	64	SPC100/5
150	145	130	2	75	SPC150/2
150	145	130	5	75	SPC150/5
200	195	180	2	81	SPC200/2
200	195	180	5	81	SPC200/5
300	291	275	2	84	SPC300/2
300	291	275	5	84	SPC300/5
450	440	380	2	71	SPC450/2
450	440	380	5	71	SPC450/5
600	592	520	2	75	SPC600/2
600	592	520	5	75	SPC600/5
800	798	725	5	82	SPC800/5
800	798	725	8	82	SPC800/8
1000	973	910	5	83	SPC1000/5
1000	973	910	8	83	SPC1000/8

RESTRAINERS FOR STRUCTURED PACKING

Structured packing such as high efficiency DURAPACK® packing (please see page 6.11) must always be very carefully fixed after installation in column sections. Otherwise there is the risk of relative movement between the jacket and the internals should any pressure surges occur and this could result in damage to the packing elements with consequent loss of performance or even disruption of operation.

For this reason, after the packing elements have been installed and spacer rings have been carefully fitted to take up any free space, a restrainer should be fitted in the coupling above the structured packing. In DN 100 to DN 300 and DN 800 and DN 1000 column sections the support rings described on page 6.13 and 6.14 also act as restrainers. In the DN 450 and DN 600 nominal bores the components described below, which perform a similar function, should be used. These are made of selected quality PTFE.

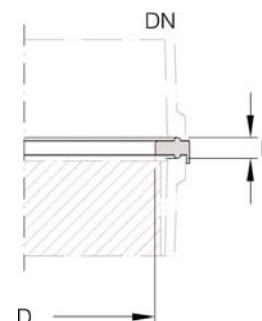

DN	D	L	Free cross-section (%)	Reference
450	380	15	71	SPST450
600	520	15	75	SPST600

COLUMN COMPONENTS

PACKING SUPPORTS FOR STRUCTURED PACKING

With all segmented, structured packing and thus also with DURAPACK® high-performance packing (please see page 6.11) it is necessary to use extra packing supports on top of the support rings described on page 6.13. These are made in a combination of borosilicate glass 3.3 and PTFE.

Details concerning free cross-sections of the supports (which have been determined in combination with a support ring) and their load-bearing capacities when loaded evenly can be found in the table below.



These packing supports are not suitable for random packing. Supports for this purpose are described on page 6.7.

In the table below »DN« refers to the nominal size of the column.

DN	D	L	E	E1	Free cross-section (%)	Load bearing capacity (N)	Reference
600	590	102	140	90	60	3600	SPP600
800	790	125	85	85	64	6000	SPP800
1000	968	125	85	85	63	8000	SPP1000

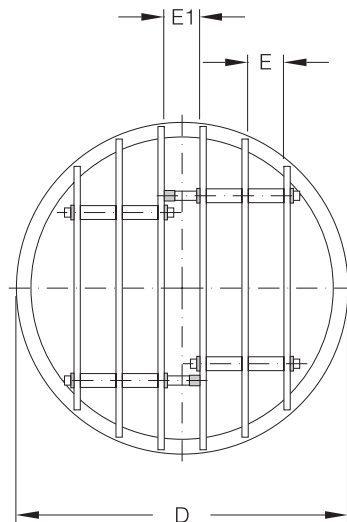
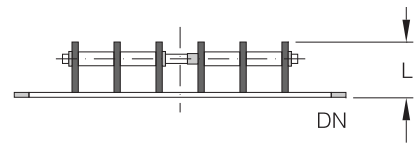

PTFE REDISTRIBUTORS

These redistributors are made of selected quality PTFE. They are clamped in the coupling of a pipe or column section in the same way as a gasket so that no additional gasket is required.

The redistributors act as simple liquid collectors and direct the liquid away from the column wall. They are, therefore, installed above redistributors and feed distributors. Their inside diameter is designed to match nozzle type distributors (please see pages 6.22 and 6.23).



DN 800 and DN 1000 nominal size column sections have an integral redistributor (please see page 6.5).

In the table below »DN« refers to the nominal size of the pipe or column section.

DN	D	H	Free cross-section (%)	Reference
25	18	6,5	52	TL25
40	28	9	49	TL40
50	35	11	49	TL50
80	55	16	47	TL80
100	70	19	49	TL100
150	105	32	49	TL150
200	140	40	39	TL200
300	200	55	44	TL300
450	315	41	49	TLN450
600	420	56	49	TLN600

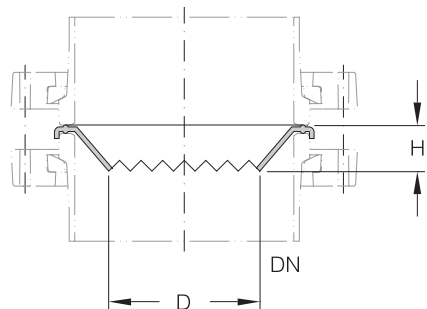

COLUMN FEED PIPES

These feed pipes can be used in diameters and types of column where it is acceptable for the liquid feed to be directed in a single stream onto the column packing.

Straight feed pipes are used as well as spray feed pipes in extraction columns to introduce the phase to be dispersed and the continuous phase.

Angled feed pipes can be used in any application where it is acceptable for the liquid feed to be directed in a single stream onto the column packing. They are usually installed via an unequal tee piece (please see section 2 »Pipeline Components«). They should not, however, be used with distribution trays.

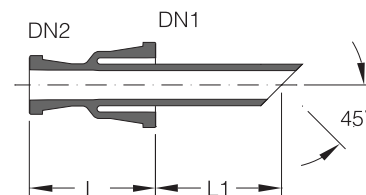

Straight Feed Pipes

DN	DN1	DN2	L	L1	Reference
80	40	25	100	100	FPS80/40
80	50	25	100	115	FPS80/50
100	40	25	100	125	FPS100/40
100	50	25	100	125	FPS100/50
150	40	25	100	150	FPS150/40
150	50	25	100	150	FPS150/50
200	40	25	100	175	FPS200/40
200	50	25	100	175	FPS200/50
300	40	25	100	225	FPS300/40
300	50	25	100	225	FPS300/50
450	80	40	125	325	FPS450/80
600	150	50	200	450	FPS600/150

COLUMN FEED PIPES

Angled Feed Pipes

DN	DN1	DN2	L	L1	d	Reference
80	40	25	100	100	13,4	FP80/40
80	50	25	100	115	13,4	FP80/50
100	40	25	100	125	13,4	FP100/40
100	50	25	100	125	13,4	FP100/50
150	40	25	100	150	13,4	FP150/40
150	50	25	100	150	13,4	FP150/50
200	40	25	100	175	13,4	FP200/40
200	50	25	100	175	13,4	FP200/50
300	40	25	100	225	13,4	FP300/40
300	50	25	100	225	13,4	FP300/50
450	80	40	125	325	24,0	FP450/80
600	150	50	200	450	37,4	FP600/150

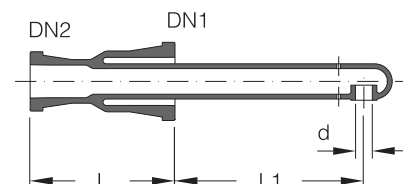

COLUMN COMPONENTS

SPRAY FEED SECTIONS WITH BUILT-IN FEED PIPE

Where there is a requirement for a finer initial distribution of the liquid stream than can be obtained with a column feed pipe (please see page 6.17) a spray feed section with built-in feed pipe can be used in the DN 100 to DN 300 nominal size range. This component delivers the liquid to the column in the form of a ring. Spray feed pipes for DN 450 and DN 600 nominal size columns can be found below.

These one-piece components comprise an unequal tee piece with a fused-in spray type feed pipe. They make it possible to use a spray type feed even in small and medium size columns.

For more specialised requirements tray, tube and nozzle type distributors can be supplied (please see pages 6.19 to 6.23).

DN	DN1	D	L	L1	n x d1	Type	Reference
100	25	45	250	110	20 x 2	A	FR100
150	25	70	250	150	27 x 2	A	FR150
200	25	90	250	175	27 x 2	B	FR200
300	25	100	300	220	30 x 3	B	FR300

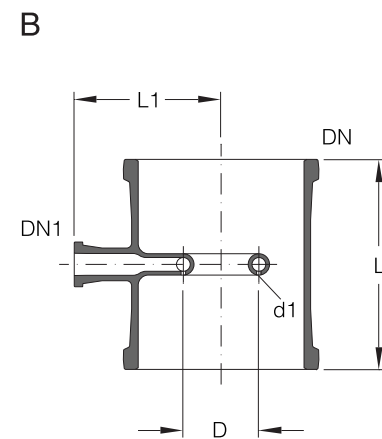
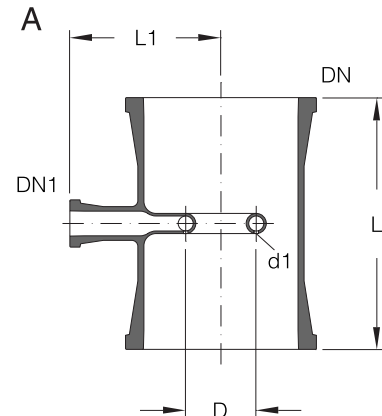

SPRAY FEED PIPES

For DN 450 and DN 600 nominal size columns these spray feed pipes are used instead of column feed pipes to provide a finer initial distribution of the liquid stream in the form of a ring. A version suitable for smaller columns can be found above.

This design, which can only be used with larger column sizes, facilitates the fitting and removal of the spray feed pipe without the need for any extensive dismantling work. This makes adaptation to changes in operating conditions a very simple matter.

For more specialised requirements tray, tube and nozzle type distributors can be supplied (please see pages 6.19 to 6.23).

 In the table below »DN« refers to the nominal size of the column.

for use with DNDN1	DN2	L	L1	L2	n x d	Reference
450						
600	150	50	200	500	40 x 3	FD450
	150	50	200	650	60 x 3	FDN600

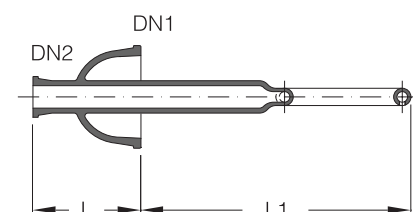
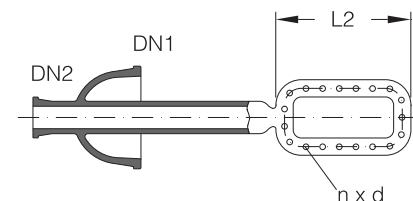

LIQUID DISTRIBUTORS

To create the conditions required for optimum mass transfer in larger nominal size columns through even distribution, we recommend the use of special components both for the first feed distribution and also redistribution in the column. Depending on the particular duty we can supply borosilicate glass 3.3 column components with sealed-in tube and channel type distributors as well as nozzle type distributors in a combination of borosilicate glass 3.3 and PTFE. The latter are fitted in distributor sections (please see page 6.23) for feed distribution duties or for use as redistributors in special column sections (please see page 6.6).

The following criteria have an important bearing on the selection of the appropriate liquid distributor:

- Process conditions such as pressure, temperature, F factor and irrigation density B_{max}
- Column diameter and type of packing
- System properties where a distinction should be made between clean (C=clean) and slightly soiled (S=soiled) systems

Liquid distributors can be selected from the table below on the basis of the nominal size of the column, irrigation density and system properties. Further data can be found in the individual product descriptions.

Tube type distributors FTD DN	Channel distributors FCD DN	Nozzle distributors FVA, FV DN	System characteristic	B_{max} approx. (m^3/m^2h)
150	-	-	C	21
200	-	-	C	17
300	-	-	C	16
450	-	-	C	17
600	-	-	C	22
-	300	-	C + S	12
-	450	-	C + S	12
-	600	-	C + S	10
-	-	200	C + S	43
-	-	300	C + S	56
-	-	450	C + S	79
-	-	600	C + S	88



All the irrigation densities indicated in this section refer to our standard version. On request, we can also supply distributors for other values.

The end form, which depends on the nominal size is shown in the diagram on page 6.2. Further information can be found in section 1 »Technical Information«.

COLUMN COMPONENTS

LIQUID DISTRIBUTORS

Channel Distributors

Where good distribution of the liquid over the whole cross section of the column is required with low irrigation densities we recommend the use of a channel distributor. The items described here are especially suitable for feed distribution of the liquid with all types of structured packing. On request, we can also supply them with an integral collecting tray for use as redistributors.

Channel distributors are one-piece borosilicate glass 3.3 components which can be fitted in columns without the need for any special adaptation. The liquid flows through drilled holes aligned in a downward direction and also through overflow pipes. The latter start to work from 40% (stage 2) or 75 % (stage 3) respectively of the maximum irrigation density onwards.

In the event of overloading, the liquid backs up along the whole length and runs off over the channel edges ensuring that irrigation of the column cross section is achieved over a large surface. Good drainage of any remaining liquid is ensured by appropriate sizing of the draining holes.

Special versions of these distributors can be supplied on request, i.e. with drop points differing from those indicated in the table below (diameter and number of holes and overflow pipes) and also in nominal sizes DN 800 and DN 1000.

DN	DN1	L	L1	L2	n x d	Type	Reference
300	25	400	175	275	32 x 3	A	FCD300
450	25	550	200	350	78 x 3	A	FCD450
600	50	600	225	450	128 x 3	A	FCD600
800	50	700	350	775	200x3	B	
1000	50	700	350	850	328x3	B	

Technical Data

DN	Free cross-section (%)	B (m ³ /m ² h)	Number of drop points per m ²
300	63	3,5 – 12	283 – 452
450	66	3 – 12	289 – 490
600	64	2,5 – 10	240 – 452
800	60	0,6 – 7,9	216 – 400
1000	62	0,6 – 8,3	219 – 418

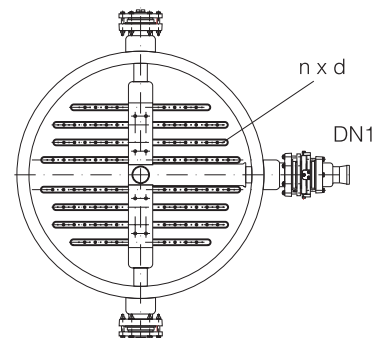
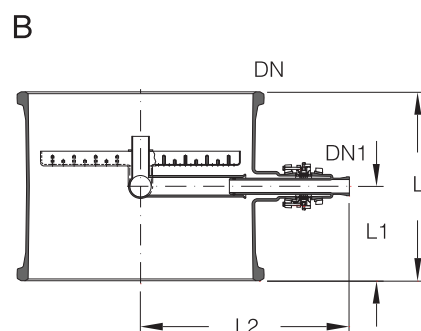
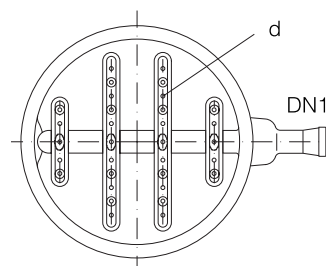
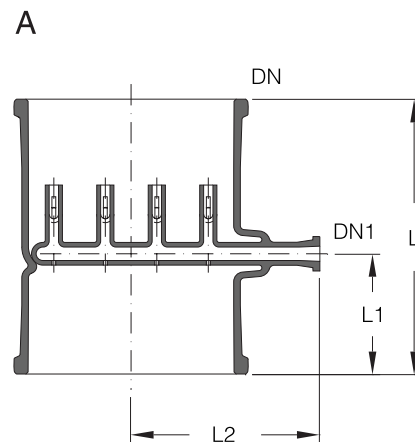

LIQUID DISTRIBUTORS

Tube Distributors

This distributor is designed for use with DURAPACK® high performance packing (please see page 6.11). It guarantees a particularly even distribution over the cross section of the column for average irrigation densities by the overflow height in the overflow pipe depending on the particular throughput. It is, therefore, particularly suitable for feed distribution with all types of structured packing. In addition, it can also be used for redistribution, if for example an »RDA..« type reflux separator is fitted above it as a collector.

Tube distributors are one-piece borosilicate glass 3.3 components which can be fitted in columns without the need for any special adaptation. The liquid flows through holes aligned in a downward direction. The horizontal tube is inclined downwards slightly to ensure good drainage.

Special versions of these distributors can be supplied on request, i.e. with drop points differing from those indicated in the table below (diameter and number of holes).

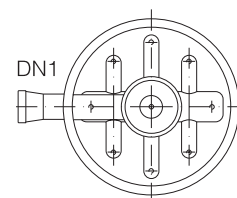
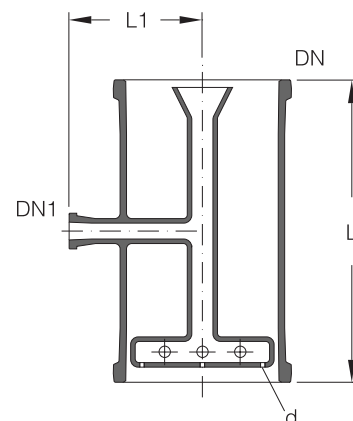

DN	DN1	L	L1	n x d	Reference
150	25	300	150	9 x 2,5	FTD150
200	25	400	175	11 x 2,5	FTD200
300	50	400	300	17 x 3	FTD300
450	80	400	375	41 x 3	FTD450
600	80	600	475	75 x 3	FTD600

Technical Data

DN	Free cross-section (%)	B (m³/m²h)	Number of drop points per m²
150	64	2,5 – 21	509
200	58	2,5 – 17	350
300	64	2,5 – 16	240
450	59	2,5 – 17	258
600	51	2,5 – 22	265

COLUMN COMPONENTS

LIQUID DISTRIBUTORS

Nozzle distributors for feed distribution

This type of distributor is ideal for high irrigation densities and widely varying throughputs. Good distribution of the liquid over the column cross section is ensured in both cases.

Nozzle distributors for feed distribution are a combination of borosilicate glass 3.3 and PTFE (nozzles only). The nozzles have lateral slits and are inserted separately in a support tray. They can, therefore, be replaced if required. The tray in turn is located on three support fingers positioned at 120° to each other and adjustable by means of a flexible gasket (see section 9 »Couplings«). A PTFE ring is fitted to prevent direct contact between the tray and the support fingers. Holes are designed to ensure good drainage when empty.

When a nozzle distributor is used for redistribution purposes an »RDA..« type reflux separator should be fitted above it with the inlet branch DN1 closed off. As an alternative we can supply the nozzle distributors described on page 6.23 which can be installed in distributor sections or column sections specially designed for the purpose.

 The supply includes the support fingers and flexible gaskets plus three flange couplings in addition to the glass jacket and complete tray.

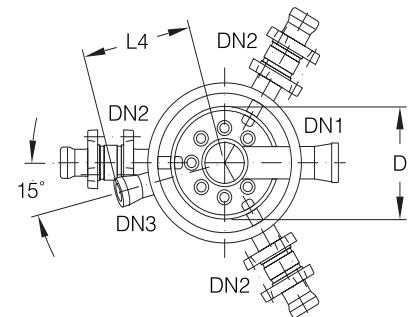
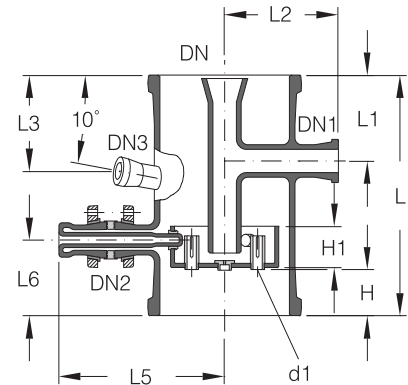

DN	DN1	DN2	DN3	D	L	L1	L2	L3	L4	L5	L6	H	H1	Reference
200	40	25	25	140	350	125	170	140	165	250	110	72	60	FVA200
300	50	25	25	231	450	150	230	165	215	300	125	87	60	FVA300
450	80	40	25	350	525	200	320	214	295	390	135	69	100	FVA450
600	80	40	25	470	600	200	400	215	375	470	175	97	110	FVA600

Technical Data

DN	Free cross-section (%)	B (m ³ /m ² h)	n x d1	Number of drop points per m ²
200	51	4,5 – 43	6 x 18	764
300	45	5 – 56	18 x 18	1018
450	44	2,5 – 79	18 x 28	453
600	44	2,5 – 88	36 x 28	509

LIQUID DISTRIBUTORS

Nozzle distributors for redistribution

These distributor trays are identical to the version supplied for the nozzle type distributors used for feed distribution described above. They can be installed, for example, in distribution sections with thermometer branch as detailed below. This results in a very compact unit that can be installed on top of standard column sections. They can also, however, be used in conjunction with column sections specially designed for this purpose (please see page 6.6). In both cases, a PTFE redistributor (please see page 6.16) should be fitted above the nozzle distributor.



The supply includes the support fingers and flexible gaskets plus three flange couplings in addition to the complete tray.

In the table below »DN« refers on the nominal size of the column.

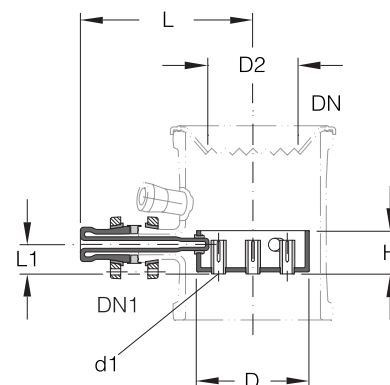

DN	DN1	D	D2	d1	L	L1	H	Reference
200	25	140	140	18	250	38	63	FV200
300	25	231	200	18	300	38	63	FV300
450	40	350	315	28	390	66	103	FVN450
600	40	470	420	28	470	78	113	FVN600

Technical Data

DN	Free cross-section (%)	B (m ³ /m ² h)	n x d1	Number of drop points per m ²
200	52	4,5 – 43	7 x 18	891
300	45	5 – 56	19 x 18	1075
450	44	2,5 – 79	19 x 28	478
600	45	2,5 – 88	37 x 28	523

LIQUID DISTRIBUTORS

Distributor sections for nozzle distributors

Fitting the nozzle distributors used for redistribution duties described above in these components with integral thermometer branch results in a very compact unit for use in columns. They have three branches at 120° to each other for the installation of the distributor tray.

DN	DN1	DN2	L	L1	L2	L3	L4	Reference
200	25	25	275	110	165	105	170	FSD200
300	25	25	300	125	218	100	220	FSD300
450	25	40	375	135	300	165	295	FSD450
600	25	40	425	175	380	170	375	FSD600

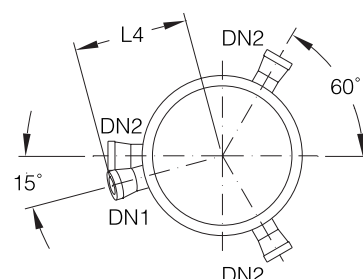
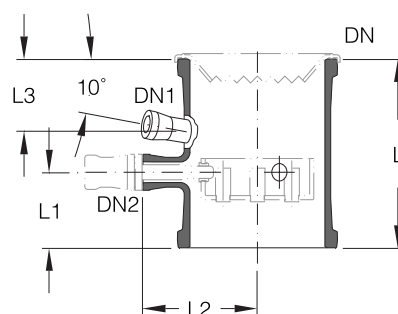

COLUMN COMPONENTS

REFLUX SEPARATORS

Reflux separators are used to control the reflux ratio in rectification columns, i.e. to separate the condensate produced into reflux and take-off streams. There are various versions available. In the manually operated version the off-take is adjusted by means of a valve on the outlet connection. The electromagnetically and pneumatically operated versions are automatically controlled in conjunction with a timer (please see section 8 »Measurement & Control«).

 The end form, which depends on the nominal size, is shown in the diagram on page 6.2. Further information can be found in section 1 »Technical Information«.

Manually Operated Reflux Separators

In these units the reflux is adjusted by means of a manually operated valve on the distillate outlet connection. When the valve is fully open the divider is set to total off-take, as the return pipe is located higher than the outlet connection. By regulating the valve, the reflux ratio can be continuously adjusted up to total reflux.

If a specific and reproducible reflux ratio is required, the use of an automatically operated reflux divider is recommended.

DN	DN1	L	L1	L2	L3	L4	α (°)	Free cross-section (%)	Type	Reference
80	25	190	104	108	126	97	30	21	A	RDA80
100	25	255	134	120	121	106	25	27	A	RDA100
150	25	255	134	145	145	111	20	21	A	RDA150
200	25	380	139	169	169	111	-	45	B	RDA200
300	25	380	139	220	220	121	-	25	B	RDA300
450	40	610	263	304	304	162	-	42	B	RDAN450
600	40	1000	288	379	379	312	10	45	C	RDAN600

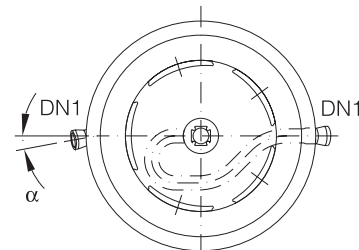
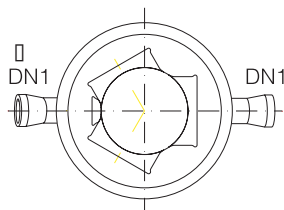
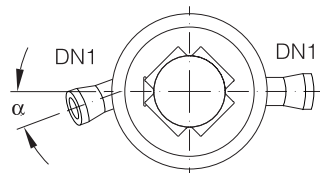
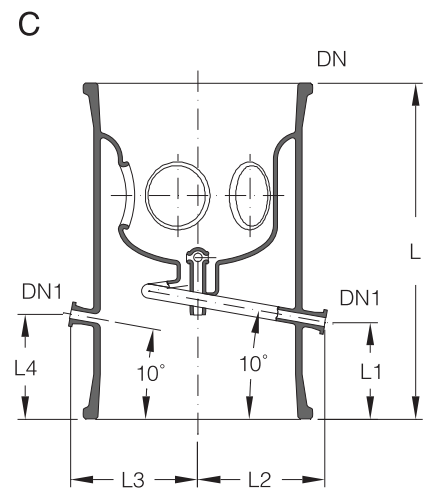
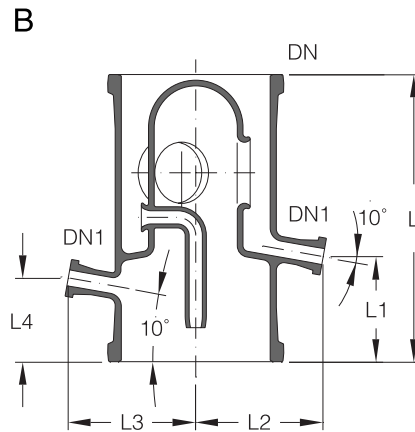
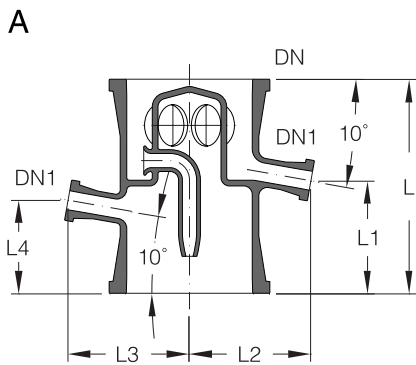

REFLUX SEPARATORS

Electromagnetically Operated Reflux Separators - Internal

This type of reflux separator uses a swinging funnel mechanism. The funnel, which has a soft iron core sealed into it, is operated magnetically from outside the column by means of a timer. When the electromagnet is not energised the funnel is at rest and all the condensate is returned to the column. Activation of the electromagnet moves the funnel into the off-take position and the distillate is removed from the column via the off-take branch.



The electromagnet and timer (see section 8 »Measurement & Control«) should be ordered separately.

To prevent vapour entering the distillate line, a liquid seal (please see page 6.28) should always be used on the off-take line.

DN	DN1	L	L1	L2	L3	L4	α (°)	β (°)	Free cross-section (%)	Reference
80	25	380	91	126	106	65	10	30	21	RHM80
100	25	455	101	118	118	80	10	30	27	RHM100
150	25	455	101	146	146	79	10	20	21	RHM150

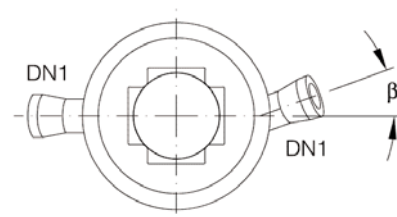
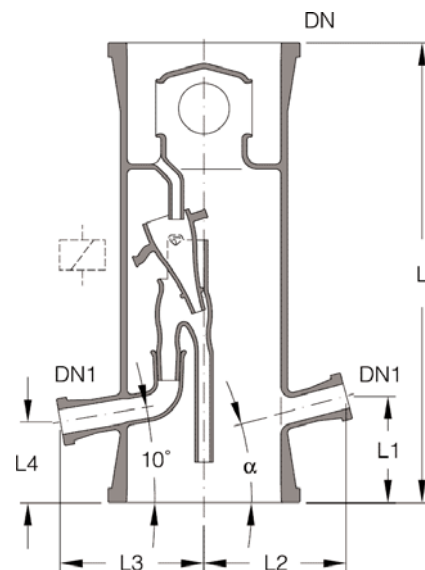

COLUMN COMPONENTS

REFLUX SEPARATORS

Pneumatically Operated Reflux Separators - Internal

This version is recommended for higher distillate volumes and columns with larger sizes. It has a swivel arm with collecting cup which is moved through a given angle by a pneumatic actuator. In one position all of the condensate is removed from the column as product and in the other position it bypasses the cup and is returned to the column.

All the parts of this version in contact with the product are borosilicate glass 3.3 or PTFE.

The pneumatic actuators used are single-acting, i.e. in the event of power failure a spring returns the unit to the safety position (total reflux). Electric and pneumatic timers are available, the former requiring the use of a solenoid control valve.



If these reflux separators are to be used in conjunction with an electric timer, a solenoid control valve is then required in the supply.

The timer required has to be ordered separately (please see section 8 »Measurement & Control«).

The operating pressure of the pneumatic drive is 2.5 bar. If a higher pressure is present in the air pressure network, a pressure reducer should be deployed within the assembly.

To prevent vapour entering the distillate line, a liquid seal (please see page 6.28) should always be used on the off-take line.

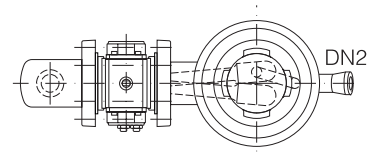
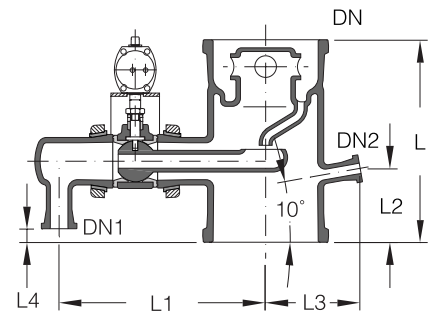

DN	DN1	DN2	L	L1	L2	L3	L4	Free cross-section (%)	Reference
200	40	25	375	399	137	175	25	16	RSP200
300	40	25	450	442	137	225	50	16	RSP300
450	40	25	550	517	162	298	50	20	RSP450
600	40	25	800	592	186	378	150	25	RSP600

REFLUX SEPARATORS

Pneumatically Operated Reflux Separators - External

This version is often used with a rectification column when a shell and tube heat exchanger is used as a condenser instead of a coil type heat exchanger.

In this reflux separator a rotating arm is rotated by a pneumatic actuator with magnetic clutch horizontally through an angle of 45° to each side. In this way the condensate, which is delivered to the separator through a side branch, can be taken off as product or returned to the column.

All the parts of this version in contact with the product are borosilicate glass 3.3 or PTFE.

The pneumatic actuators used are single-acting or double-acting. In the event of power failure a spring returns the single-acting unit to the safety position (total reflux). Electric and pneumatic timers are available, the former requiring the use of a solenoid control valve.



If these reflux separators are to be used in conjunction with an electric timer, they should be ordered using the corresponding catalogue reference from the table below. The solenoid control valve is then included in the supply (hazardous area type EEx ia IIC T6).

The timer required has to be ordered separately (please see section 8 »Measurement & Control«).

The operating pressure of the pneumatic drive is 2.5 bar. If a higher pressure is present in the air pressure network, a pressure reducer should be deployed within the assembly.

To prevent vapour entering the distillate line, the off-take line from these reflux separators should be designed to form a liquid seal.

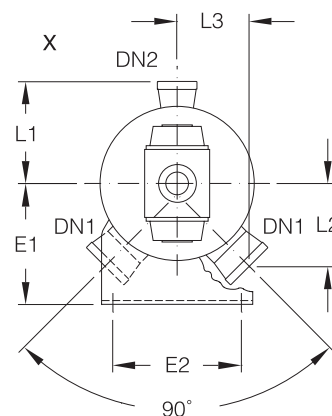
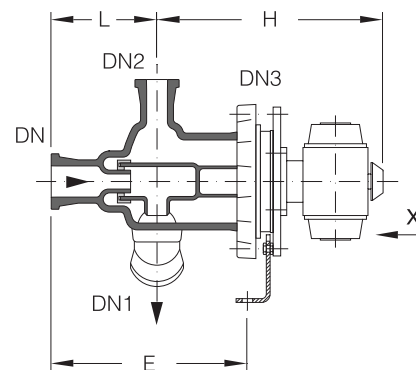

DN	DN1	DN2	DN3	L	L1	L2	L3	E	E1	E2	H	Reference
40	50	25	100	140	135	110	96	260	160	170	300	FT100/...

Type of pneumatic actuator	Reference
Single action	FT100/1
Single action with 3/2-way solenoid valve 24VDC	FT100/2
Double action	FT100/3
Double action with 5/2-way solenoid valve 24VDC	FT100/4

COLUMN COMPONENTS

LIQUID SEALS

Liquid seals are fitted on the off-take branch of automatically operated reflux separators to prevent the passage of vapours into the distillate line. A drain valve can be fitted so that the liquid seal can be fully drained.

 If the condensate undergoes after-cooling in an »HEF.« type product cooler (please see section 5 »Heat Exchangers«), a liquid seal should not be used.

DN	DN1	L	L1	Reference
25	25	160	205	LS25
40	25	315	305	LS40

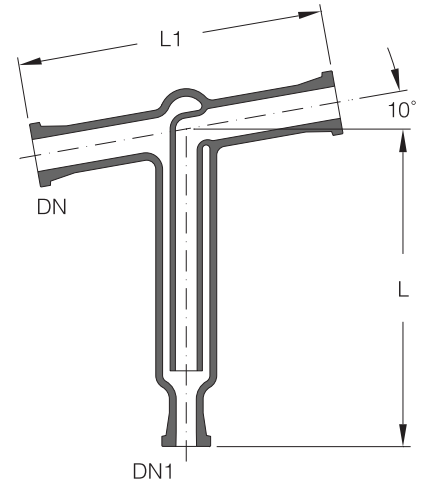

COLUMN ADAPTORS

These items, which are available in two different versions, are used as the top component in rectification and absorption columns. Depending on the particular duty and availability of space either a round top or flat top column adaptor can be selected.

Flat Top Column Adaptors

Flat top column adaptors have a small side branch as standard. This type is usually selected where the available headroom is restricted.

We can also supply flat top column adaptors with larger side branches, although this results in an increase in overall height.

DN	DN1	L	L1	L2	Type	Reference
150	40	155	165	110	A	FH150/40
200	40	175	175	125	B	FH200/40
300	40	200	225	125	B	FH300/40
450	40	275	300	150	B	FH450/40
600	40	325	375	175	B	FH600/40

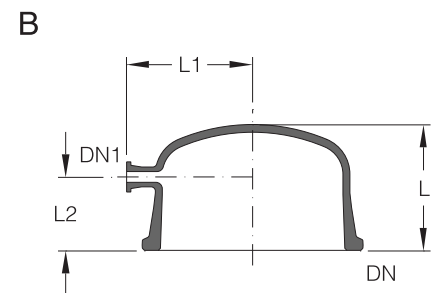
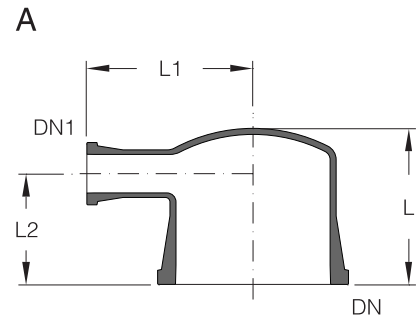

COLUMN ADAPTORS

Round Top Column Adaptors

The side branch on this version provides a large free cross-section, as required for example to facilitate connection to an external shell and tube condenser (please see section 5 »Heat Exchangers«) and/or a vacuum pump.

All round top adaptors also have an additional branch that can be used, for example, to insert a measuring probe.

DN	DN1	DN2	L	L1	L2	Type	Reference
80	40	25	180	110	90	A	CA80/40/25
100	50	25	230	125	125	A	CA100/50/25
150	50	25	240	150	125	A	CA150/50/25
150	80	25	255	165	125	A	CA150/80/25
200	50	40	350	175	125	B	CA200/50/40
200	80	40	375	200	150	B	CA200/80/40
200	100	40	425	225	175	B	CA200/100/40
200	150	40	450	250	200	B	CA200/150/40
300	50	40	425	225	150	B	CA300/50/40
300	80	40	475	250	175	B	CA300/80/40
300	100	40	475	275	175	B	CA300/100/40
300	150	40	550	300	225	B	CA300/150/40
450	80	50	575	325	200	B	CA450/80/50
450	150	50	675	375	250	B	CA450/150/50
450	200	50	750	350	300	B	CA450/200/50
600	80	50	750	400	300	B	CA600/80/50
600	150	50	800	450	300	B	CA600/150/50
600	200	100	850	425	300	B	CA600/200/100
600	300	100	850	500	400	B	CA600/300/100
800	200	150	1250	575	500	B	CA800/200/150
800	300	150	1250	650	500	B	CA800/300/150
1000	200	150	1300	675	500	B	CA1000/200/150
1000	300	200	1300	750	500	B	CA1000/300/200

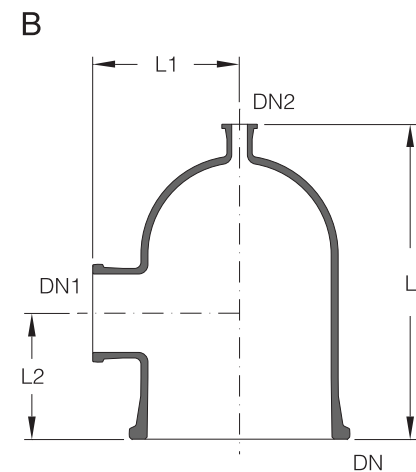
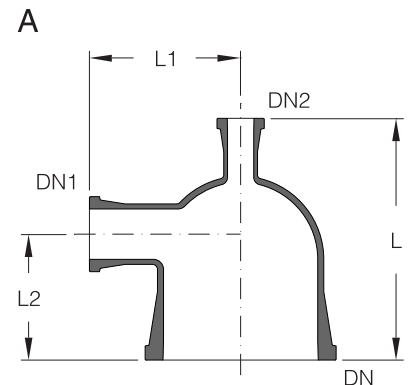

COLUMN COMPONENTS

COLUMN SECTIONS WITH GLASS/PTFE BUBBLE-CAP PLATES

There are two different versions of columns with bubble cap plates available with borosilicate glass 3.3/PTFE/tantalum bubble-caps or with stainless steel bubble-caps (please see page 6.31). The actual column section is borosilicate glass 3.3 in both cases.

Column sections specifically designed for the purpose are used to provide correct support for the plates, to ensure that they are firmly fixed on the underside and to ensure a permanently reliable edge seal. This is achieved by reducing the cross-section of the outer jacket within sufficiently close tolerances at the appropriate points and using a PTFE sealing ring. The glass plates and sealing rings are also braced within the column by means of tantalum hooks as protection against pressure surges.

The standard bubble-caps supplied have a relatively low pressure drop. These bubble-caps can, however, be supplied with risers on, as these are better suited for use as scrubbers which are downstream of batch processes. This ensures that the scrubbing liquid is retained on the plates when vapour flow is halted for short periods.

Glass pipes are used as downcomers, with a cross-section selected for the liquid loading for the particular application. The bottom column section requires a downcomer fitted with a dip pot to provide a liquid seal. Both versions, i.e. with and without dip pot, can be found in the table below

Further information on column sections with bubble-caps such as areas of application, operating range, flooding point and pressure drop can be found in our special brochure "Column Sections with Random and Structured Packing and Internals".

 The normal weir height of the downcomers is 30 mm. If other heights are required, please indicate on the order.

If bubble-caps are required with riser, please add »K« to the catalogue reference (for example »BCSAK..«). The relative free cross-section area is reduced to approximately 83 % in this case (please see Technical Data).

Borosilicate glass 3.3 bubble-caps and plates made from other materials can also be supplied on request.

The end form, which depends on the nominal size, is shown in the diagram on page 6.2. Further information can be found in section 1 »Technical Information«.

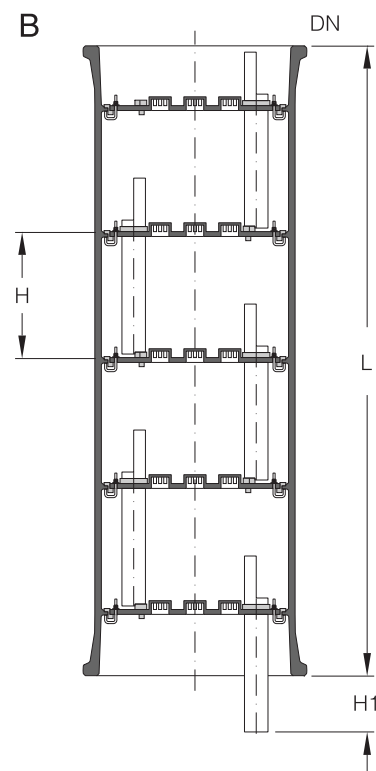
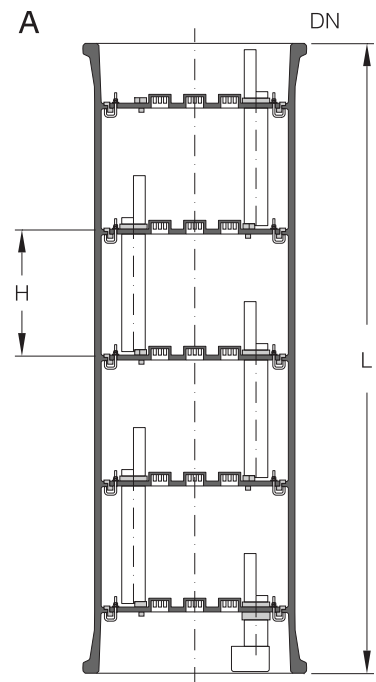

DN	L	H	H1	Number of plates approx.	Caps per plate	Down-comers per plate	Reference with dip pot	Reference without dip pot
							Type A	Type B
200	1000	200	91	5	2	1	BCSA200/1000	BCS200/1000
300	1000	250	116	4	5	1	BCSA300/1000	BCS300/1000
450	1500	300	141	5	13	2	BCSA450/1500	BCS450/1500
600	1500	375	179	4	24	2	BCSA600/1500	BCS600/1500

Technical Data

DN	Bubble cap slit	Free cross-section without riser (5%)	Free cross-section with riser (5%)	Weir height downcomer
	H x B			
200	16 x 3	6,4	3,9	30
300	16 x 3	7,1	4,4	30
450	16 x 3	8,2	5,0	30
600	16 x 3	8,5	5,2	30

COLUMN SECTIONS WITH STAINLESS STEEL BUBBLE-CAP PLATES

There are two different versions of columns with bubble cap plates available: with stainless steel bubble-caps or with borosilicate glass 3.3 bubble-caps (please see page 6.30). The actual column section is borosilicate glass 3.3 in both cases.

The stainless steel bubble-cap internals are completely preassembled and then integrally fitted into precision bore borosilicate glass 3.3 pipe sections so that their performance can be visually monitored at all times. The seal between the bubble-cap plates and the pipe section is made with specially designed PTFE seals.

The original version of the bubble-cap design was a single bubble-cap sized to provide optimum vapour and liquid cross sectional areas. It has now been modified and adapted to the tube diameters to ensure that the column sections are suitable for high vapour and liquid loading with small tray spacing and ensure a consistently high level of efficiency over a wide operating range.

To achieve these benefits in their entirety, various designs of bubble-cap have been selected. In the DN 80 and DN 100 nominal sizes kidney-shaped bubble-caps are used and circular bubble-caps in DN 150.

Further information on column sections with bubble-caps such as areas of application, operating range, flooding point and pressure drop can be found in our special brochure "Column Sections with Random and Structured Packing and Internals".

 Bubble-cap internals and column sections can also be supplied on request in other materials.

DN	L	H	H1	H2	H3	H4	Number of plates	Caps per plate	Reference
80	1009	80	42	-	-	6	11	1	CSG80/1000
100	1007	111	47	-	45	-	9	1	CSG100/1000
150	1010	200	109	145	64	-	5	1	CSG150/1000

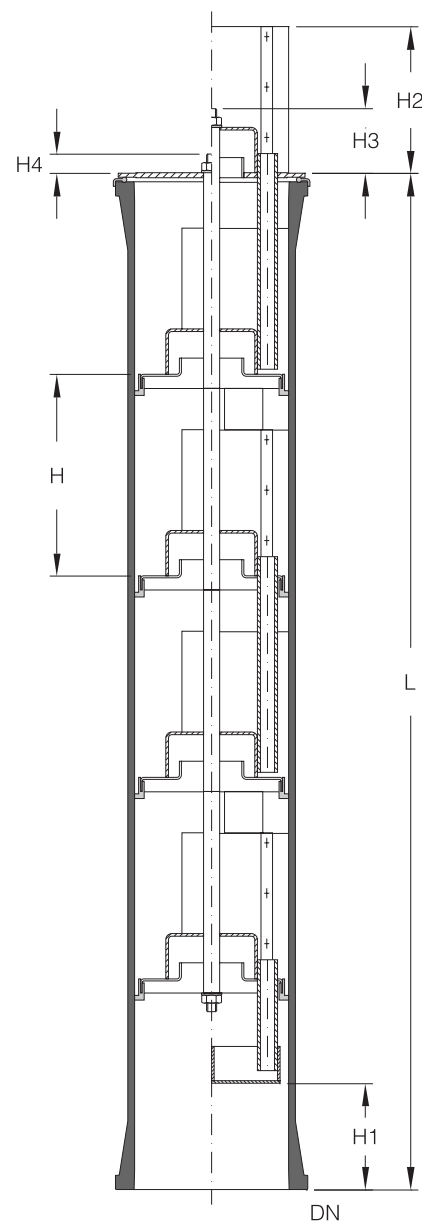

COLUMN COMPONENTS

PRECISION BORE PIPE SECTIONS

The special feature of these components is their very closely toleranced internal diameter between the buttress ends. Together with precision bore cylinders (please see below) they provide a technical and cost-effective solution where column sections are required for special internals such as high efficiency packing and bubble-cap plates with edge seal or sieve plates without edge seal.

 In addition to the standard sizes listed below we can also supply pipe sections in other lengths and for higher operating pressures.

The end form, which depends on the nominal size, is shown in the diagram on page 6.2. Further information can be found in section 1 »Technical Information«.

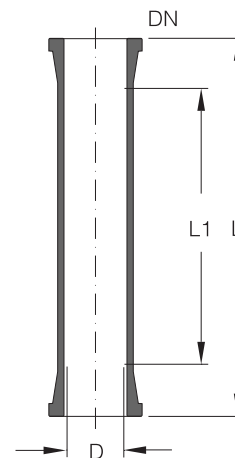

DN	D	L	L1	Reference
25	25 ± 0,1	1000	860	CPS25/1000/860
40	38 ± 0,1	1000	860	CPS40/1000/860
50	50 ± 0,2	1000	860	CPS50/1000/860
80	75 ± 0,3	1000	860	CPS80/1000/860
100	100 ± 0,4	1000	820	CPS100/1000/820
150	150 ± 0,4	1000	800	CPS150/1000/800
200	200 ± 0,5	1000	800	CPS200/1000/800
300	296 ± 0,6	1000	720	CPS300/1000/720
450	446 ± 0,7	1000	660	CPS450/1000/660

PRECISION BORE CYLINDERS

These pipes have no buttress ends and have a very closely toleranced internal diameter over their whole length. They are normally used for chromatography columns and are clamped between two other components.

We would be happy to advise you on suitable design measures.

 In addition to the standard sizes listed below we can also supply cylinders in other lengths and for higher operating pressures.

DN	D	L	P _{max} , 20°C (bar)	Reference
300	296 ± 0,5	1000	3	CCY300/1000
450	446 ± 0,6	1000	1,5	CCY450/1000
600	590 ± 1,5	1000	1	CCY600/1000

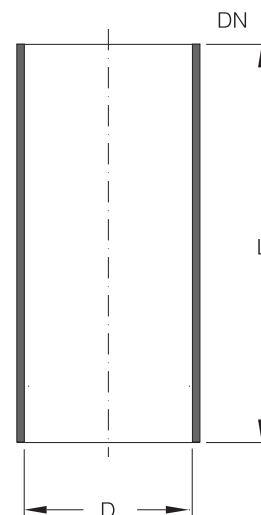

FILTER PLATES

These porous plates are made of sintered glass powder. They have fused edges and can be clamped between standard safety buttress ends. They are used to introduce gases into columns, for example, in bubble columns, or as filter strainers to separate solids from liquids (e.g. in precious metal separation units) operating under vacuum.

These filter plates are available in three different porosity ranges. Further information on this can be found in the table below.

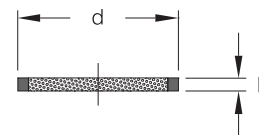

DN	d	L	Porosity	Reference
50	70	20	0-2	FIL50/...
80	100	20	0-2	FILN80/...
100	130	20	0-2	FILN100/...
150	185	16	0-2	FIL150/...
200	235	19	0-2	FIL200/...

Porosity	0	1	2
	150	90	40
Nominal value of the maximum pore diameter (µm)	to	to	to
	200	150	90



When ordering, please add the code number for the porosity required (please see above) to the catalogue reference.

The permissible pressure difference for all filter plates is 1 bar.