



**QVF**

PROCESS PLANT COMPONENTS



## General

QVF measurement and control equipment complements the component range and ensures that borosilicate glass 3.3 plant and apparatus operates safely. In addition to commercially available equipment, which we always fall back on if it complies with our corrosion resistance requirements, we also offer a range of special items (in particular transducers) developed either by ourselves or in cooperation with well-known companies.

Above all, because of their corrosion resistance, our transducers are widely used in the chemical and pharmaceutical industries and also in a wide range of related areas, as well as food and drinks manufacturing, dyeing and the electroplating industry. The special properties of borosilicate glass 3.3 and tantalum contribute to this plus the fact that borosilicate glass 3.3 is an approved and tried and tested material for the construction of pressure vessels.

The full range of standard equipment is described on the following pages. Reference is made in the particular product description of special versions that can be supplied on request.



In addition to the individual items of equipment we can also supply complete control loops, measurement and control systems and process control systems including the necessary documentation and control panels subject to the relevant regulations in each case (e.g. CENELEC).

## GMP Compliant Installations

The use of transducers and, where required, the layout of interconnecting pipework incorporating valves when constructing plant and apparatus complying with GMP guidelines calls for special care in the design and selection of the components used and the materials of construction employed for them. Because of its special properties that are so highly valued in the pharmaceutical industry in conjunction with the PTFE materials (gaskets, special parts, bellows) approved in accordance with the FDA catalog, borosilicate glass 3.3 guarantees that the build-up of deposits is prevented in areas in contact with the product. The design and arrangement of many transducers results in the avoidance of any dead space and ensures that they can be fully drained and easily and effectively cleaned. Appropriate stainless steel coupling and support materials are available (please see section 9 "Couplings" and section 10 "Structures") to ensure that the external design of these assemblies meets clean room requirements.

## Permissible Operating Conditions

While the permissible operating temperature for all borosilicate glass 3.3 components is generally 200°C, the permissible positive operating pressure is dependent on the main nominal size and not on the shape of the component.

Detailed information on this can be found in section 1 "Technical Information".

## PRINCIPLES OF EXPLOSION PROTECTION

The installation and operation of electrical equipment in hazardous areas is covered by the "Regulations for electrical installations in potentially explosive atmospheres ExeV".

### EC Directive 94/9/EC (ATEX 100a)

This directive regulates the suitability of equipment and protective systems intended for use in potentially explosive atmospheres and lays down fundamental safety requirements.

### Fundamental Technical Principles

Classification of zones Hazardous areas are classified into zones based on the frequency and duration of the occurrence of explosive atmospheres. Information and guidelines on the classification of zones can be found in IEC 60079-10 and national standards.

In **Zones 0 and 1** only electrical equipment may be used for which a certificate of conformity or a type examination certificate exists; in **Zone 0**, however, only apparatus specifically certified for this purpose may be installed. The table below provides an overview of the classification of zones and indicates the apparatus applicable to the particular zone.

Gases, vapours, mists	Category	Potentially explosive atmosphere present (in accordance with 94/9/EC)
Zone 0	1 G	Continuously or for long periods or frequently
Zone 1	2 G	Occasionally
Zone 2	3 G	Rarely or for short periods

Dusts are classified in Zones 20, 21 and 22 and correspond to Categories 1D, 2D, 3D (D = Dusts).

### Explosion groups

Electrical equipment is differentiated into two groups:

Group I: Electrical equipment for mining.

Group II: Electrical equipment for the chemical industry, petrochemical industry, mills, etc.

### Temperature classes

The maximum surface temperature of electrical equipment must always be lower than the ignition temperature of the gas or vapour/air mixture where it is to be used.

Equipment that meets a higher temperature class (e.g. T5) can of course also be used in applications requiring a lower temperature class (e.g. T2 or T3).

### Permissible surface temperature of the electrical equipment

T1	T2	T3	T4	T5	T6
450 °C	300 °C	200 °C	135 °C	100 °C	85 °C

### Certification and marking

Marking in accordance with EN 50014

[ E Ex ia ] IIC T6

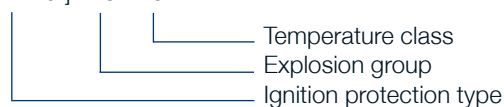

Additional marking in accordance with EC Directive 94/9/EC (ATEX 100a)

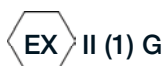

## THERMOMETERS FOR LOCAL DISPLAY

These are supplied as standard with safety flat buttress end and can be fitted in DN 25 nominal size measuring branches. The measuring range is 0 to 200 °C.

Thermometers for local display are made of 16 III Normalglas. They are mainly used in laboratories and pilot plants and are available in three different versions. The angled versions are mainly used in column adaptors, spherical vessels and columns. Because of the properties of the mechanical sensors severe turbulence should be avoided in the measuring vessel. The thermometers are filled with light oil (petroleum).



As these thermometers are made from 16 III Normalglas (equivalent to N16B thermometer glass) it is not possible to make them in DN 40. It is, therefore, necessary to specify a spherical vessel with a DN 25 side branch when using a THL45/... thermometer.

Our 45° and 90° angled thermometers have a scale that can be rotated through 360° for ease of legibility.

Thermometers with limit contact can be found on page 8.7.

## THERMOMETERS FOR LOCAL DISPLAY

### Straight Thermometers

DN	L	H	d	Reference
25	100	265	15	THL100
25	150	265	15	THL150
25	200	265	15	THL200
25	300	265	15	THL300

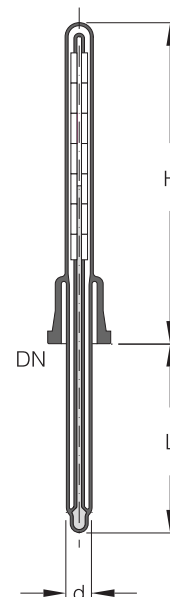

## THERMOMETERS FOR LOCAL DISPLAY

### 90° Angled Thermometers

DN	L	H	H1	d	Reference
25	100	265	100	15	THL90/100
25	150	265	100	15	THL90/150
25	200	265	100	15	THL90/200
25	300	265	100	15	THL90/300

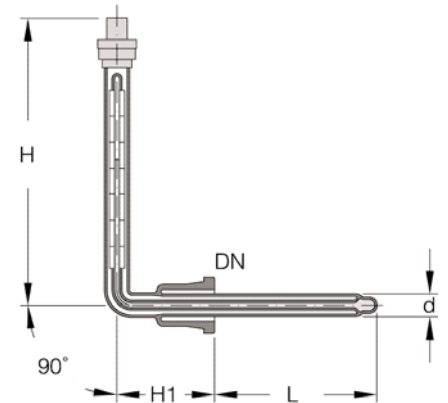

## THERMOMETERS FOR LOCAL DISPLAY

### 45° Angled Thermometers

DN	L	L1	H	H1	d	for spherical vessel (l)	Reference
25	160	115	255	90	15	10	THL45/160
25	210	125	255	90	15	20	THL45/210
25	300	150	255	90	15	50	THL45/300
25	375	135	255	90	15	100	THL45/375
25	475	155	255	90	15	200	THL45/475

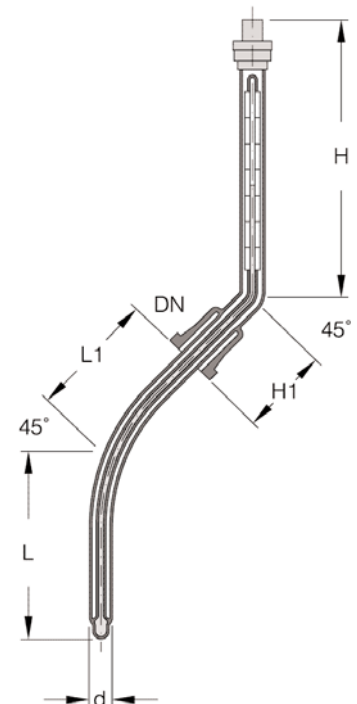

## REMOTE DIAL THERMOMETERS

These remote-reading dial thermometers are supplied for direct temperature measurement in parts of plant where access is difficult. The display can be mounted in an easily visible place on the support structure by means of a bracket that is included in the scope of supply and suitable for pipe diameters between 20 and 80 mm. The measuring probe is located in a glass protective sheath at the measuring point.

A 3 m long stainless steel flexible capillary is used to connect the display and the sensor. To achieve better heat transfer the tip of the protective sheath is filled with silicone heat transfer paste.

These remote dial thermometers can also be supplied with an inductive max. contact (THLDC.). They then comply with the requirements applicable to Group II electrical equipment for use in category 2G (zone 1) hazardous areas.

### Technical data

Display	Diameter	- 100 mm (nominal size)
	Measurement range	- 0-120 °C (2 °C graduations)
	Measurement accuracy	- Class 1 without glass protective sheath
	Housing temperature	- -20 to +65 °C
	Measurement principle	- Gas pressure (inert gas filling)
	Protection type	- IP 56
Contact device (Type THLDC)	Version	- inductive
	Type of explosion protection	- II 2 G, EEx ia IIC T6
	Switching function	- Max. contact, closing with increasing temperature
	Cable connection	- Plug with screw connection
Dip tube:	Diameter	- 10 mm
Remote line (capillary)	Diameter x length	- 2 x 3000 mm
Materials	Display	- Stainless steel
	Dip tube/remote line	- Stainless steel
	Bracket	- Steel, galvanised



On request we also supply these remote dial thermometers for other measuring ranges (e.g. 0 – 200 °C) and remote line lengths.

Remote dial thermometers with contact device require the use of an appropriate isolating switching amplifier.

## REMOTE DIAL THERMOMETERS

### Remote Dial Thermometer without Contact\*

DN	L	H	H1	H2	H3	E	D	d1	Type	Reference
25	100	105	430	19	50	85	100	20	A	THLD25/100
25	150	105	430	19	50	85	100	20	A	THLD25/150
25	200	105	430	19	50	85	100	20	A	THLD25/200
25	300	105	430	19	50	85	100	20	A	THLD25/300

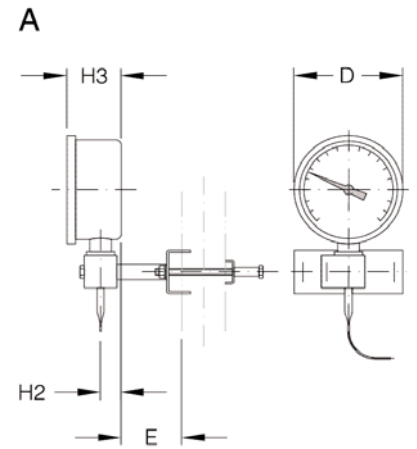

### Remote Dial Thermometer with Contact \*

DN	L	H	H1	H2	H3	H4	E	D	d1	Type	Reference
25	100	105	430	19	103	84	85	100	20	B	THLDC25/100
25	150	105	430	19	103	84	85	100	20	B	THLDC25/150
25	200	105	430	19	103	84	85	100	20	B	THLDC25/200
25	300	105	430	19	103	84	85	100	20	B	THLDC25/300

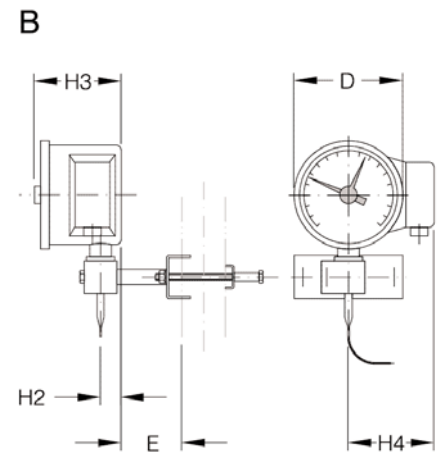

\*for A , B

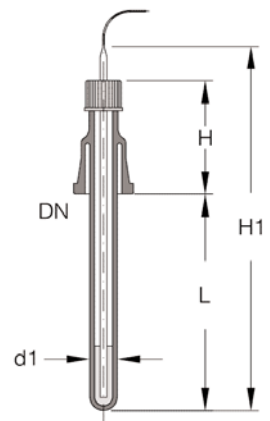

## RESISTANCE THERMOMETERS FOR CATEGORY 2G HAZARDOUS AREAS

If there is a requirement to transfer temperatures to a control room or a process control system, resistance thermometers can be used as transmitters. They comply with the requirements applicable to Group II electrical operating equipment for use in category 2G (zone 1) hazardous areas.

The interchangeable measuring sensor used in these resistance thermometers comprises a stainless steel tube with a Pt 100 built-in four-wire measuring element. This is fitted in a virtually universally corrosion resistant borosilicate glass 3.3 protective sheath with heat transfer paste in the tip. The polyamide head is firmly fixed to the glass part with adhesive.

The "THRT.." version has a transmitter built into its head and this can be retrofitted in the "THR.." version or located in the control room. However, in the case of the "THR.." the transmitter is not part of the scope of supply.

Resistance thermometers can be supplied optionally with straight or angled stems (for spherical vessels) and they can be installed in DN 25 and DN 40 nominal size safety flat buttress ends respectively.

### Technical data

Measuring probe	Resistance element	- 1x Pt 100 to IEC 751, Class A, 4-wire
	Permissible product temperature	- -50 to +200 °C
Head	Version	- BUKH shape
	Cable connection	- Screw connection, blue
	Permissible ambient temperature	- -45 to +85 °C
Transmitter (built-in, Type THRT)	Measuring range (standard)	- 0 to 200 °C
	Output signal	- 4 to 20 mA, 2-wire
	Type of explosion protection	- II 1G EEx ia IIC T6
Materials	Thermometer	- Stainless steel
	Protective sheath	- Borosilicate glass 3.3
	Head	- Polyamide, black
Type of explosion protection	Measuring probe	- II 2G EEx ia IIC T6



On request we can also supply resistance thermometers with transmitters (Type THRT) for different measurement ranges.

Resistance thermometers for Group II for use in Category 1G (Zone 0) hazardous areas can be found on page 8.10 .

## RESISTANCE THERMOMETERS FOR CATEGORY 2G HAZARDOUS AREAS

### Straight Thermometers

DN	L	H	H1	d	Reference without transmitter	Reference with transmitter
25	100	183	104	22	THR25/100	THRT25/100
25	150	183	104	22	THR25/150	THRT25/150
25	200	183	104	22	THR25/200	THRT25/200
25	300	183	104	22	THR25/300	THRT25/300
40	200	183	104	22	THR40/200	THRT40/200
40	300	183	104	22	THR40/300	THRT40/300
40	500	183	104	22	THR40/500	THRT40/500

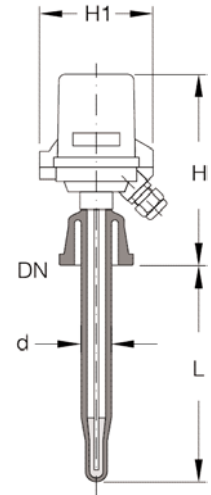

## RESISTANCE THERMOMETERS FOR CATEGORY 2G HAZARDOUS AREAS

### 45° Angled Thermometers

DN	L	L1	H	H1	d	for spherical vessel (l)	Reference without transmitter	Reference with transmitter
40	160	120	183	104	22	10	THR45/40/160	THRT45/40/160
40	210	130	183	104	22	20	THR45/40/210	THRT45/40/210
40	300	157	183	104	22	50	THR45/40/300	THRT45/40/300
40	375	140	183	104	22	100	THR45/40/375	THRT45/40/375
50	475	170	193	104	22	200	THR45/50/475	THRT45/50/475

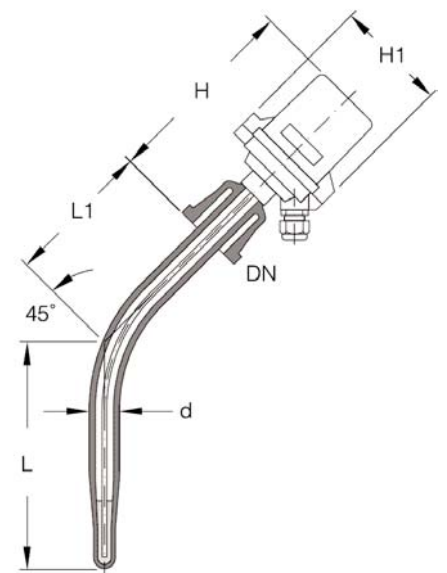

## RESISTANCE THERMOMETERS FOR CATEGORY 1G / 2 (1) G HAZARDOUS AREAS

If there is a requirement to transfer temperatures to a control room or a process control system, resistance thermometers can be used as transmitters. The THRX range complies with the requirements applicable to Group II electrical operating equipment for use in category 1G (zone 0) hazardous areas.

These devices consist essentially of a resistance thermometer with stainless steel guard tube, screw-in thread and connection head plus a virtually universally corrosion resistant borosilicate glass 3.3 protective sheath. The two parts are joined together by means of a connecting piece, the contour of which is the same as a safety flat buttress end, and a standard flange coupling.

A four-wire Pt 100 resistor acts as the measuring element. The measuring tip of the resistance thermometer is inserted in a heat transfer paste.

The "THRXT.." version (Category 2 (1) G) has a transmitter built into its head and this can be retrofitted in the "THRX.." version or located in the control room. However, in this case the transmitter is not part of the scope of supply.

Resistance thermometers can be installed in measuring branches with DN 25 and DN 40 nominal size safety flat buttress ends respectively.

### Technical data

Measuring probe	Resistance element	- 1x Pt 100 to IEC 751, Class A, 4-wire
	Permissible product temperature	- -50 to +200 °C
Head	Version	- BUKH shape
	Cable connection	- Screw connection, blue
	Permissible ambient temperature	- -45 to +85 °C
Transmitter (built-in, Type THRXT)	Measuring range (standard)	- 0 to 200
	Output signal	- 4 to 20 mA, 2-wire
	Type of explosion protection	- II 2 (1) G EEx [ia] ib IIC T6
Materials	Thermometer	- Stainless steel
	Protective sheath	- Borosilicate glass 3.3
	Head	- Polyamide, black
Type of explosion protection	Measuring probe	- II 1G EEx ia IIC T6



On request we can also supply resistance thermometers with transmitters (Type THRXT) for different measurement ranges.

Thermometers with transmitter type THRXT are only approved for use in category 2 (zone 1) due to the ex protection type of the transmitter. Yet, they may be used for a unit in category 1.

## RESISTANCE THERMOMETERS FOR CATEGORY 1G / 2 (1)G HAZARDOUS AREAS

### Resistance Thermometers

DN	L	H	H1	d	Reference without transmitter Category 1 G	Reference with transmitter Category 2 (1)G
25	100	275	104	22	THR25/100	THRXT25/100
25	150	275	104	22	THR25/150	THRXT25/150
25	200	275	104	22	THR25/200	THRXT25/200
25	300	275	104	22	THR25/300	THRXT25/300
40	200	275	104	22	THR40/200	THRXT40/200
40	300	275	104	22	THR40/300	THRXT40/300
40	500	275	104	22	THR40/500	THRXT40/500

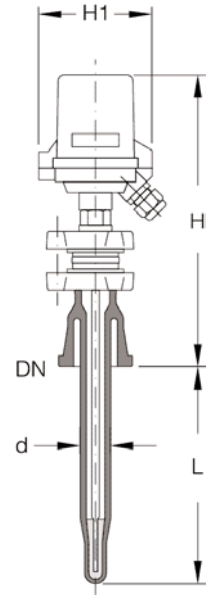

## PRESSURE GAUGES

These pressure measurement instruments can be connected to glass branches and with their flush laser-welded tantalum diaphragm they guarantee a corrosion-resistant, dead-space-free and GMP compliant arrangement of measuring points. As the contour of the pressure gauge is the same as a pipe section with safety flat buttress end, it can be connected directly to DN 25 nominal size measuring branches using a standard flange coupling.

The pressure gauges can be supplied for three measuring ranges and optionally with an inductive max. contact as well. With this contact they then comply with the requirements applicable to Group II electrical operating equipment for use in category 2G (zone 1) hazardous zones.

### Technical data

Display	Diameter	- 100 mm (nominal size)
	Measurement range	- see table
	Measurement accuracy	- Class 1
	Indicator	- Microadjustable pointer
	Protection type	- IP 65
Pressure gauge	Filled with	- Synthetic food oil
	Permissible temperature range	- see instrument data
	Permissible positive pressure	- 1.3 x upper limit of measuring range
Contact device (Type PGLC)	Version	- inductive
	Type of explosion protection	- II 2G EEx ia IIC T6
	Switching function	- Max. contact, closing with increasing pressure
	Cable connection	- Plug with screw connection
Pressure gauge materials	Basic body	- Stainless steel
	Diaphragm	- Tantalum (laser welded)



On request we can also supply these pressure gauges with different measurement ranges.

Pressure gauges with contact device require the use of an appropriate isolating switching amplifier.

Flange contour also suitable for connection to Schott flange with standard Schott coupling.

For use under vacuum in plants complying with GMP guidelines for the -1 to +1.5 bar measuring range a standard 'O' ring gasket (type TR) should be included.

The pressure gauges can be used at temperatures from -50 to +200°C, although the accuracy is limited to the temperature range given in the table.

## PRESSURE GAUGES

### Pressure gauges without Contact Device

DN	Measuring range n. Class 1 (bar)	Temperature range (°C)	H	H2	H3	D	Type	Reference
25	-1 to +1,5	+20 to +140	150	60	15	100	A	PGL1.5
25	0 to +2,5	-10 to +200	150	60	15	100	A	PGL2.5
25	0 to +6,0	-10 to +200	150	60	15	100	A	PGL6

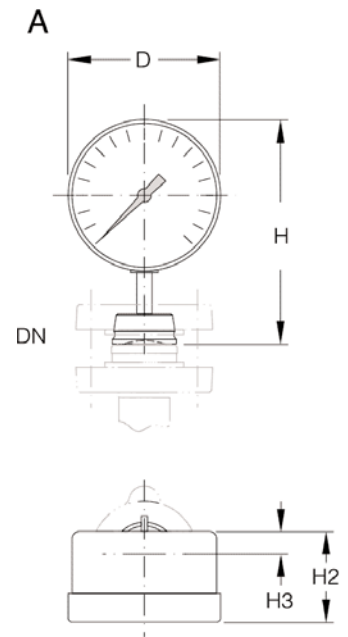

## PRESSURE GAUGES

### Pressure gauges with Contact Device

DN	Measuring range n. Class 1 (bar)	Temperature range (°C)	H	H1	H2	H3	D	Type	Reference
25	-1 to +1,5	+20 to +140	150	89	112	15	100	B	PGLC1.5
25	0 to +2,5	-10 to +200	150	89	112	15	100	B	PGLC2.5
25	0 to +6,0	-10 to +200	150	89	112	15	100	B	PGLC6

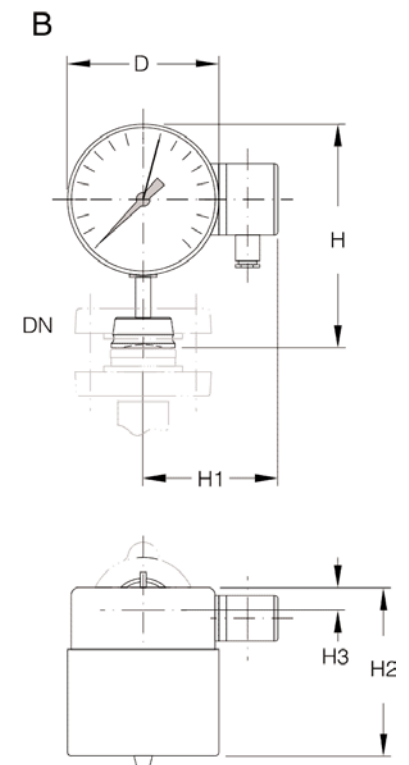

## PRESSURE TRANSMITTERS

If there is a requirement to transfer pressure data to a control room or a process control system, these devices can be used as transducers. The attached pressure gauge with its flush laser-welded tantalum diaphragm guarantees a corrosion-resistant, dead-space-free and GMP compliant arrangement of measuring points. As the contour of the pressure gauge is the same as a pipe section with safety flat buttress end, it can be connected direct to DN 25 nominal size measuring branches using a standard flange coupling.

These pressure transmitters comply with the requirements applicable to Group II electrical operating equipment for use in Category 1G (zone 0) hazardous areas.

### Technical data

Pressure transmitter	Measurement ranges	- See table
	Measurement accuracy	- $< \pm 0.2\%$ of final value at 20 °C
	Zero point error	- 4.8 mbar/10 K
	Output signal	- 4 to 20 mA, 2-wire, HART optional
Protection type	Operated by	- Graphic display German/English
	- IP 65	
Pressure gauge	Filled with	- Vacuumoil
	Permissible temperature range	- -40 to +200 °C
	Overload limit	- 6/10 bar abs.
Pressure gauge materials	Basic body	- Stainless steel
	Diaphragm	- Tantalum (laser welded)
Type of explosion protection		- II 1/2G EEx ia IIC T6



On request we can also supply these pressure transmitters with different measurement ranges.

For use of plants complying with GMP guidelines under vacuum a standard 'O' ring gasket (type TR) should be included.

Flange contour also suitable for connection to Schott flange with standard Schott coupling.

DN	Measuring range (mbar abs)	H	H1	H2	H3	Reference
25	0 to 4000	245	63	62	119	PGT4000

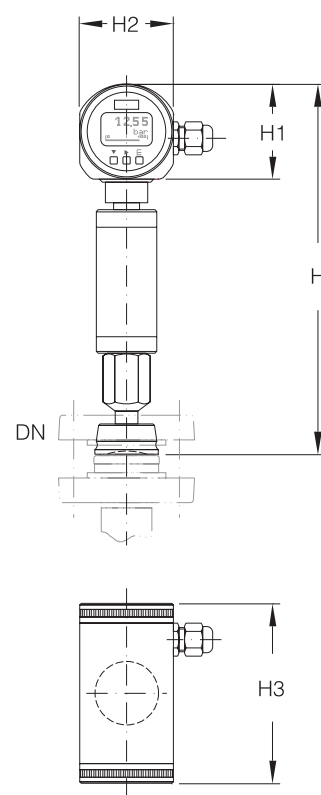

## THERMOMETER POCKETS WITH SCREW CAP

These thermometer pockets are designed for use with stem type thermometers or other temperature probes. Improved heat transfer can be achieved by filling the pocket with a contact fluid or heat transfer paste.

DN	L	L1	H	d	d1	d2	d3	Type	Reference
25	100	-	105	20	16	10	-	A	TPG25/100
25	150	-	105	20	16	10	-	A	TPG25/150
25	200	-	105	20	16	10	-	A	TPG25/200
25	300	-	105	20	16	10	-	A	TPG25/300
40	200	150	115	28	16	10	20	B	TPG40/200
40	300	150	115	28	16	10	20	B	TPG40/300
40	500	150	115	28	16	10	20	B	TPG40/500
40	650	150	115	28	16	10	20	B	TPG40/650
40	850	150	115	28	16	10	20	B	TPG40/850

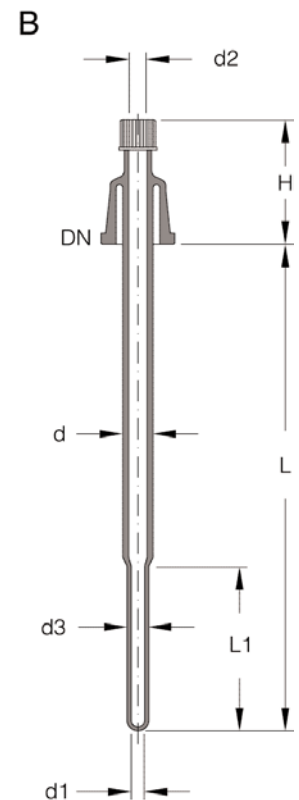
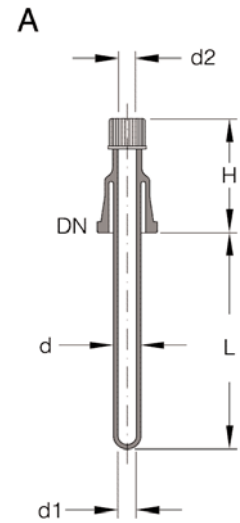

## FLOWMETERS

These devices use a float to determine the volume of liquid or gas flowing through. They consist of a calibrated measuring tube made of borosilicate glass 3.3 with an etched scale (graduated in mm), the PTFE float and upper and lower PTFE float traps. Also included in the scope of supply is a calibrated scale clamped to the measuring tube and calibrated to water (at 20 °C).. Details of the measuring ranges can be found in the table on page 8.17.

To ensure accurate measurement, flowmeters must be fitted in an absolutely vertical position and in DN 80 and above a 5xDN calming zone must be provided before the device. Measurement accuracy conforms to Class 1.6.

Operating temperature: -50 to +150°C.



Other calibrated scales can be supplied if required for special liquids/gases and operating conditions. In such cases the following information should be specified:

- Liquid/gas
- Measuring range in l/h or Nm<sup>3</sup>/h
- Density in kg/l or kg/Nm<sup>3</sup>
- Viscosity in mPa·s
- Operating temperature in °C
- Operating pressure in bars
- Nominal size of the pipeline

In the case of repeat orders we need the catalogue reference of the flowmeter and the serial number of the etched scale.

## FLOWMETERS

DN	Water (l/h) 20°C	Air (m <sup>3</sup> /h) * 1bar abs, 20°C	L	Reference
25	0,2 – 4	0,010 – 0,18	350	FML25/4
25	0,5 – 10	0,020 – 0,4	350	FML25/10
25	2 – 40	0,1 – 1,6	350	FML25/40
25	4 – 63	0,2 – 2,4	350	FML25/63
25	15 – 160	0,6 – 6,3	350	FML25/160
25	40 – 400	1,6 – 16	350	FML25/400
40	60 – 630	2,5 – 25	350	FML40/630
40	100 – 1000	4 – 40	350	FML40/1000
50	60 – 630	2,5 – 25	350	FML50/630
50	100 – 1000	4 – 40	350	FML50/1000
80	160 – 1600	6,3 – 63	350	FML80/1600
80	250 – 2500	10 – 100	350	FML80/2500
80	400 – 4000	16 – 160	350	FML80/4000
80	630 – 6300	25 – 250	350	FML80/6300

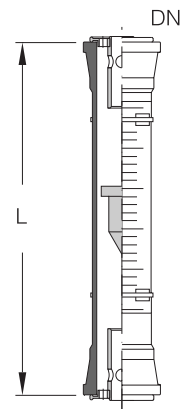

\* Valves given for air serve as orientation guide and require a special scale.

## FLOWMETERS WITH ELECTRICAL OUTPUT

These devices use a float to determine the volume of liquid or gas flowing through. They consist of a transducer with local display, an attached calibrated measuring tube made of borosilicate glass 3.3, a PTFE-sheathed float fitted with a magnet, and upper and lower PTFE float traps. The 350 mm long measuring tubes have safety flat buttress ends at both ends. Details of the measuring ranges can be found in the table below.

The position of the float is determined by magnetic sensors and this information is converted into an electrical output signal.

To ensure accurate measurement, flowmeters must be fitted in an absolutely vertical position and in DN 80 and above a 5xDN calming zone must be provided before the device. Measurement accuracy will then conform to Class 2.5.

On request we can supply these devices with up to two inductive limit switches programmable from the scale suitable for II 2G EEx ia IIC T6 hazardous area protection for max. or min. signalling as the case may be. These can also be retrofitted.

The device is also fitted with a LCD display from which the flow rate at the particular time or the cumulative flow quantity (switchable) can be read off digitally.

### Technical data

Display	Dimensions	- Ø161 mm
	Display range	- l/h and m <sup>3</sup> /h respectively
	Digital display	- 8-digit, 7-segment, LCD
	Measurement accuracy	- Class 2.5
	Display scale	- Flow units l/h and m <sup>3</sup> /h respectively Standard: Water 20 °C
	Protection type	- IP 67
Measuring tube	Version:	- Conical glass tube
	Permissible operating temperature	- -50 to +130 °C
Transducer	Measurement range	- See table
	Output signal	- 4 to 20 mA, 2-wire
	Type of explosion protection	- II 2G EEx ia IIC T6
	Ambient temperature	- -25 to +70 °C
	Cable thread	- M16 x 1.5
Materials	Measuring tube	- Borosilicate glass 3.3
	Measuring tube internals	- PTFE and PTFE-sheathed respectively
	Transducer casing	- Stainless steel
Type of explosion protection		- II 2G EEx ia IIC T6



If to be designed for liquids or gases other than water or air the following information should be specified:

- Liquid/gas
- Measuring range in l/h or m<sup>3</sup>/h
- Density in kg/l or kg/m<sup>3</sup>
- Viscosity in mPa·s
- Operating temperature in °C
- Operating pressure in bars
- Nominal size of the pipeline

In the case of repeat orders or changes to the product data we need the catalogue reference and the serial number of the flowmeter.

## FLOWMETERS WITH ELECTRICAL OUTPUT

DN	Water (l/h) 20°C	Air (m <sup>3</sup> /h) 1 bar abs, 20°C	L	D	H	H1	Reference
25	16 – 160	0,5 – 5	350	161	129	11	FMT25/160
25	25 – 250	0,85 – 8,5	350	161	129	11	FMT25/250
25	40 – 400	1,3 – 13	350	161	129	11	FMT25/400
25	63 – 630	2 – 20	350	161	129	11	FMT25/630
25	100 – 1000	3,4 – 34	350	161	129	11	FMT25/1000
40	160 – 1600	5 – 50	350	161	136	11	FMT40/1600
40	250 – 2500	8,5 – 85	350	161	136	11	FMT40/2500
50	160 – 1600	5 – 50	350	161	136	11	FMT50/1600
50	250 – 2500	8,5 – 85	350	161	136	11	FMT50/2500
80	400 – 4000	13 – 130	350	161	151	11	FMT80/4000
80	630 – 6300	20 – 200	350	161	151	11	FMT80/6300
80	1000 – 10000	35 – 350	350	161	151	11	FMT80/10000
80	1600 – 16000	–	350	161	151	11	FMT80/16000

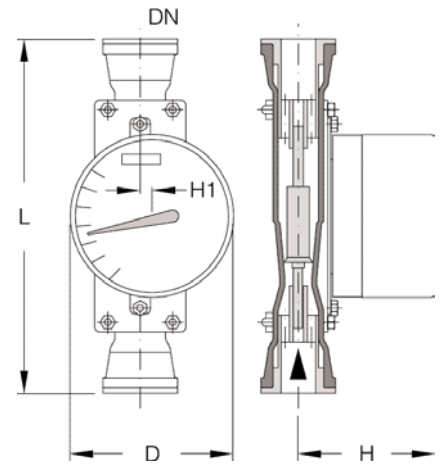

## ELECTRIC LEVEL CONTROL

This comprises a DN 25 nominal size bypass tube, in which a glass float with a built-in magnet moves up and down, and an externally fitted bistable max. and min. contact which is set or reset when the float passes it completely.

The standard scope of supply includes the borosilicate glass 3.3 float, two cast limit switches (function: max. and min. closing with reference to the up and down travel of the float) with pipe supports and two PTFE float traps. These limit the movement of the float to the range being monitored. Further limit switches (see below) can be used for extra signalling of alarm situations. A DN 25 bypass tube of the length required should be ordered separately.



The limit switches must be fitted with a contact protection relay or an isolating switching device with a II 2G EEx ia IIC T6 input.

### Wiring diagram

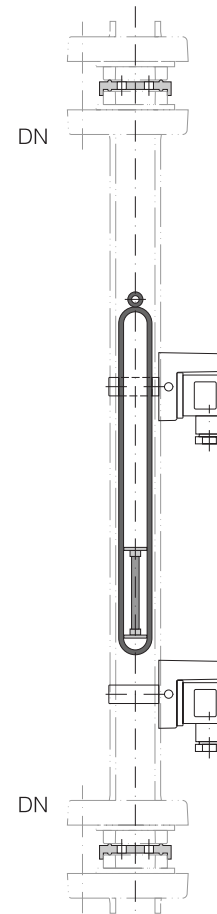
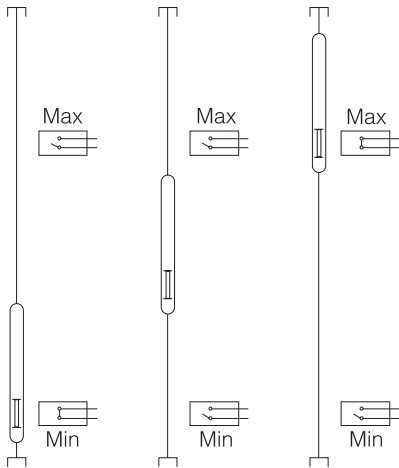

DN	Reference
25	LEC25

## ELECTRIC LEVEL CONTROL

### Magnetic Float for Level Control

The magnetic floats used in the type "LEC..." level controls are suitable for use with liquids having a density between 0.8 and 1.2 kg/dm<sup>3</sup>. On request, however, we can also supply these floats for lower densities.

 The "DN" figure in the table below refers in all cases to the nominal size of the bypass tube.

Float traps to suit these floats (see below) should be ordered separately.

DN	L	d	Reference
25	238	22	LEC25-1

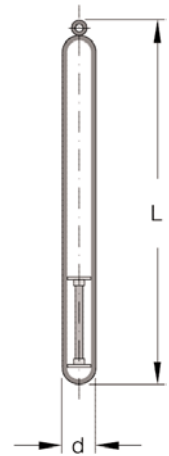

### Limit Switches for Level Control

The standard switches used with the type "LEC..." level controls are the closing type. They store the particular switching point and remain closed until the float passes them in the opposite direction.

 The switches are supplied with the pipe clamps required.

DN	H	H1	H2	Function	Reference
25	60	63	30	Max. close	LEC25-2
25	60	63	30	Min. close	LEC25-3

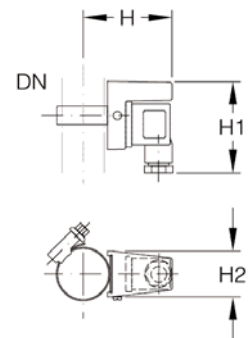

### Float Traps for Level Control

The float traps listed here are used with type "LEC..." level controls. They are fitted above and below the magnetic float in one of the couplings used with the bypass tube. They have a built-in bead on both sides for sealing purposes and, therefore, there is no need for a separate gasket.

DN	L1	n x d1	Reference
25	5,5	3 x 6	LEC25-4

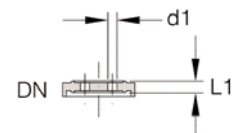

## ELECTRICAL LEVEL MEASUREMENT DEVICE

This comprises a DN 50 nominal size bypass tube containing a glass float with built-in magnet. An externally fitted level transmitter contains a chain of resistors with dedicated reed contacts. The change of the resistance is converted by a flow converter in to a 4 to 20 mA signal.

The standard scope of supply includes the measuring tube, the borosilicate glass 3.3 float, the transmitter complete with fixings (pipe supports with support rings), two PTFE float traps and the connecting housing with built-in type II 2G EEx ia IIC T6 transmitter. The 4 to 20 mA output signal is available in a 2-wire version and must be supplied by an appropriate supply device. The measuring device can thus be operated in hazardous areas.

The float traps are built into the upper and lower measuring tube couplings and limit the movement of the float to the range to be measured. They have a built-in bead on both sides for sealing purposes and, therefore, there is no need for a separate gasket.

Floats are available for two density ranges (see below). The depth of immersion in both cases is between 50 and 90 %. The position of the resistor chain is arranged in relation to them in such a way that the magnet switches the first and last reed contact (0 to 100 % of the level) at the maximum and minimum float position respectively. The contact grid selected as a function of the length of the measuring range (distance between the bypass tube connections) guarantees a good resolution. Further details can be found in the table below.

DN	Density (kg/dm <sup>3</sup> )	L	L1	L2	L3	M	Contact grid (mm)	Reference
50	0,7 – 1,25	500	141	198	80	100	5	LET50/1.25/500A
50	0,7 – 1,25	700	141	198	80	300	5	LET50/1.25/700A
50	0,7 – 1,25	1000	141	198	80	600	10	LET50/1.25/1000A
50	0,7 – 1,25	1500	141	198	80	1100	10	LET50/1.25/1500A
50	0,7 – 1,25	2000	141	198	80	1600	20	LET50/1.25/2000A
50	0,8 – 1,50	500	141	98	80	200	5	LET50/1.50/500A
50	0,8 – 1,50	700	141	98	80	400	5	LET50/1.50/700A
50	0,8 – 1,50	1000	141	98	80	700	10	LET50/1.50/1000A
50	0,8 – 1,50	1500	141	98	80	1200	10	LET50/1.50/1500A
50	0,8 – 1,50	2000	141	98	80	1700	20	LET50/1.50/2000A

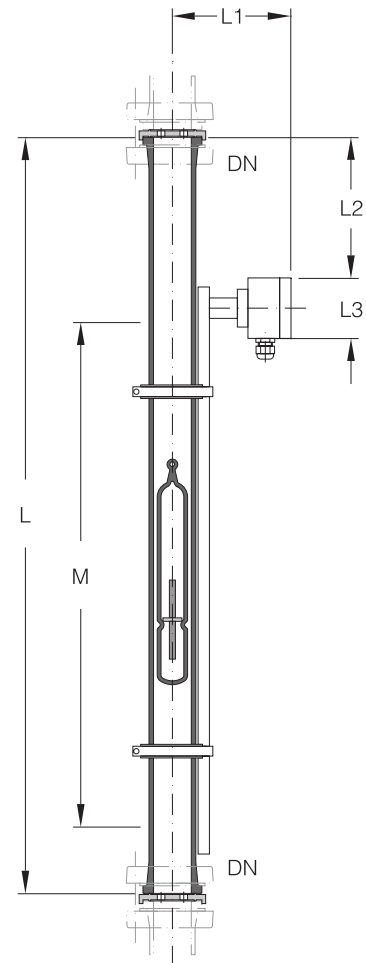

## ELECTRICAL LEVEL MEASUREMENT DEVICE

### Magnetic Float for Electrical Level Measurement Device

On request we can also supply floats for type "LET..." level measurement devices for other density ranges. Float traps to suit these (see below) should be ordered separately.



The "DN" figure in the table below refers to the nominal size of the bypass tube.

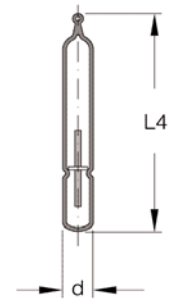

DN	Density (kg/dm <sup>3</sup> )	L4	d	Reference
50	0,7 – 1,25	400	46	LET50/1.25-2
50	0,8 – 1,50	300	46	LET50/1.50-2

## ELECTRICAL LEVEL MEASUREMENT DEVICE

### Float Traps for Electrical Level Measurement Device

The float traps for the type "LET..." level measurement device are fitted above and below the magnetic float in the measuring tube coupling. They have a built-in bead on both sides for sealing purposes and, therefore, there is no need for a separate gasket.

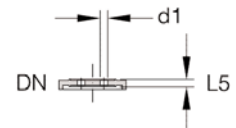

DN	L5	n x d1	Reference
50	8	3x10	LET50/1.25-3

## MAGNET FOR REFLUX SEPARATORS

These 'U' magnets are used with Type RHM reflux separators. Used in conjunction with an electrical timer module a movable funnel with an iron core sealed into the glass located inside the column can be operated from outside.

### Technical data

Supply	DC voltage	- 24 VDC +6 / -10 %
	Nominal current	- 0.622 A
	Connecting cable	- 3x1.5 mm <sup>2</sup> , 1.5 m long
	Max. permissible ambient temperature	- -5 to +40 °C
Materials	Housing	- Aluminium, varnished
	Moulding	- Polyurethane-based
Protection type	Housing	- IP 54
	Explosion protection	- II 2 G EEx m II T4

DN	H	H1	H2	H3	Reference
80	175	200	90	120	RSM80
100	192	234	90	120	RSM100
150	218	239	100	157	RSM150

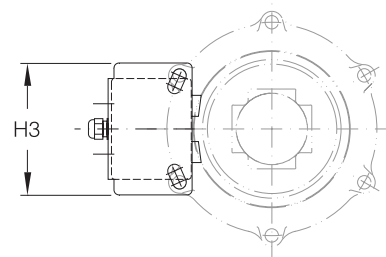
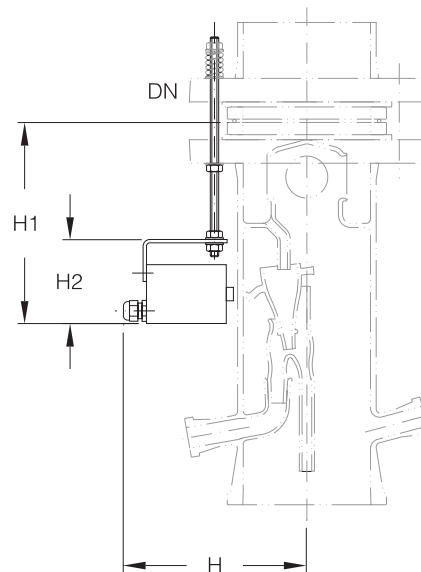

## ELECTRIC TIMER

This is an electronic timer used for controlling the reflux ratio in rectification columns with electromagnetically or pneumatically operated reflux separators with magnetic control valves. The reflux and offtake times can be adjusted on the timer from 1 to 99 seconds. The boiling point is monitored with a resistance thermometer (Pt 100) and this intervenes in the control so that when a preset temperature is reached the timer switches to total reflux or offtake and gives a warning that this has happened by sounding an alarm. When a second cut-off value (hysteresis value from 1 to 9 seconds presettable) is reached, the control returns to the preset timing cycle. There are 4 keys on the front panel which are used to enter all the preset values. Additionally there are 3 different programs available:

- Program 0: all functions operating,
- Program 1: alarm off, fault warning off
- Program 2: Pt100 off, output signal off, fault warning off

### Timer Module for Rack Mounting

The control unit described above is supplied as timer module type TMM01 for rack mounting.

### Timer for hazardous areas, Category 2G

For use in hazardous areas the timer module type TMM01 is built into an EEx de (ia) IIC pressure resistant housing and can thus be used as a type TMX01 Group II, Category 2G hazardous area timer.

### Technical data

Input	Pt 100	- 1x Pt 100, 3 to 4 wire
	Power supply	- 24 VDC, 5A
Output	Analog signal	- 4-20 mA
	Time	- Transistor 24 VDC max. 3A
	Cut-off value 1	- Relay max. 40 VDC, 800 mA
	Cut-off value 2	- Relay max. 40 VDC, 800 mA
Materials	Housing TMM01	- Makrolon
	Housing TMX01	- Light metal
Protection type	Housing TMR01	- IP 50 (Front)
	Housing TMX01	- IP 65

H	H1	D	Type	Reference
72	135	-	A	TMM01
145	244	140	B	TMX01

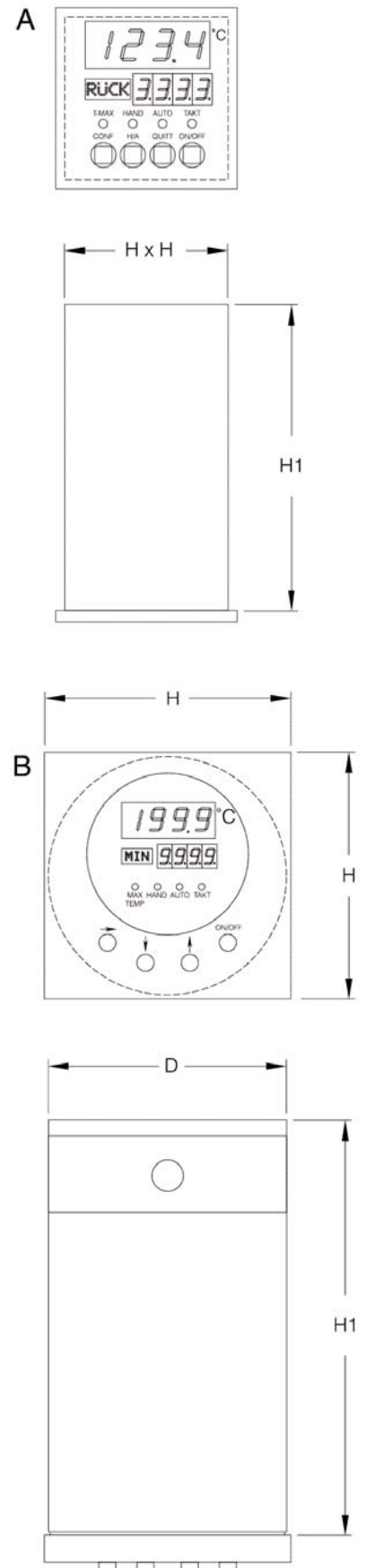

## PNEUMATIC TIMER

The TMXP controller is a pneumatic timer used for controlling pneumatic reflux separators. As it operates completely pneumatically, it can be used without restriction in hazardous areas. The reflux and offtake times can be adjusted on the timer from 0.3 to 10 seconds or alternatively from 0.3 to 100 seconds. There are two buttons which can be used, when the timer is set to "Manual", to switch it to total offtake or total reflux. When set to "Automatic" the timer starts the preset reflux ratio. Whether set to "Manual" or "Automatic" the instrument display panel indicates the current position of the reflux separator (reflux or offtake).

H	H1	H2	E	d	Reference
300	380	210	420	12	TMXP

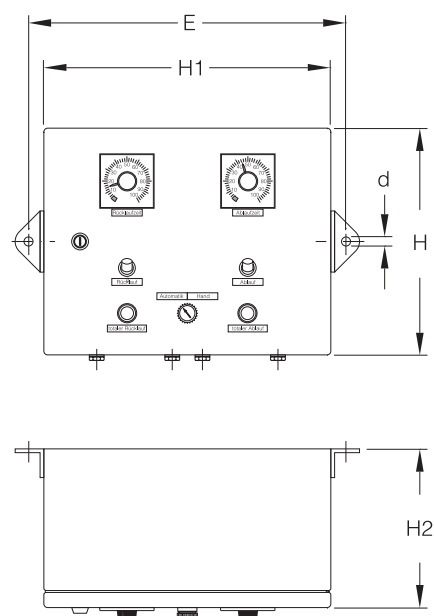

## ELECTRODES

### FOR PH, REDOX AND CONDUCTIVITY MEASUREMENT

The equipment available for process monitoring and control of pH, Redox and conductivity includes borosilicate glass electrode measuring chambers with PTFE flange. Up to two commercially available electrodes with PG 13.5 thread and 120 mm long can be fitted in the PTFE flange. One screw thread is blanked off as standard. The maximum operating temperature is 120 °C. The choice of a suitable electrode is governed by the process conditions.



If glass electrodes cannot be used for conductivity measurement, we can also supply inductive measuring cells for the measuring chamber.

Straight and angled dip tubes can be supplied in various lengths for use in columns, receivers and spherical vessels.

### Electrode Measuring Chambers

DN	DN1	DN2	L	L1	H	D	Reference
25	40	15	200	83	98	105	QIP25

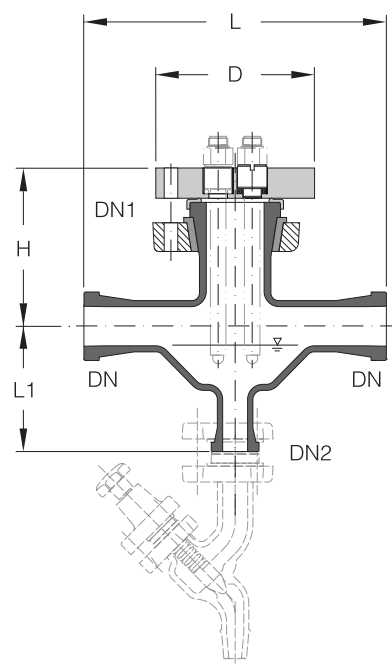

## ELECTRODES FOR PH, REDOX AND CONDUCTIVITY MEASUREMENT

Straight and angled probes are suitable for process monitoring in columns and vessels. The dip tubes are made of borosilicate glass 3.3 and include a PTFE assembly, in which a standard electrode with PG 13.5 thread and 120 mm length may be fitted. The seal between glass and PTFE assembly is made of viton.

The maximum operating temperature is 120°C.

### Straight Dip Tubes

DN	L	H	D	Reference
40	500	128	37	QID40/500
40	650	128	37	QID40/650
40	850	128	37	QID40/850

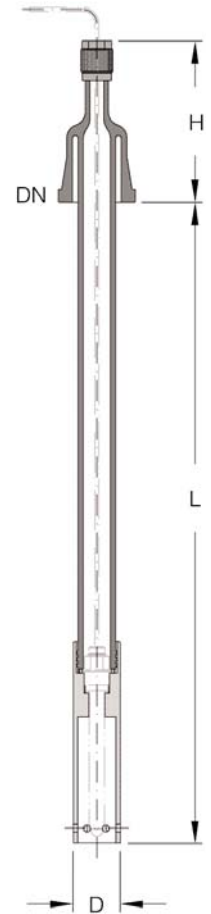

### Angled Dip Tubes for Installation in Spherical Vessels

DN	L	L1	H	D	for spherical vessel (l)	Reference
40	275	150	128	37	50	QID45/40/275
40	350	150	128	37	100	QID45/40/350
50	450	150	138	37	200	QID45/50/450

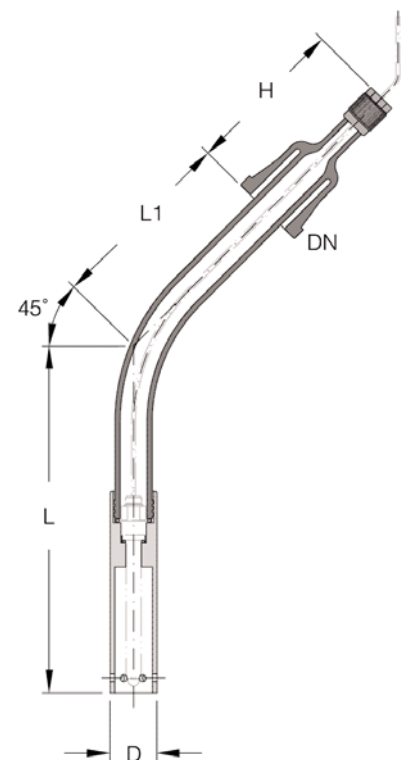

## ELECTRICAL INTERFACE MEASUREMENT

Float type measuring instruments are used for interface measurement in extraction columns. The float's magnet system activates a resistor chain in the guide tube which corresponds to a 3-wire potentiometer circuit. A 2-wire measurement transformer in the connection housing converts the resistor chain signal with a 5 mm contact grid to 4-20 mA.

These floats can only be installed from above in a branch with a minimum size of DN 80. The density of the heavy phase must be at least 0.70 kg/dm<sup>3</sup>.

### Technical data

Supply	Control voltage	- 24VDC 2-wire
	Output signal	- 4-20 mA
	Ambient temperature	- max. 70 °C
Materials	Connection housing	- Aluminium
	Flange	- Stainless steel
	Wetted	- Stainless steel
Protection type	Housing	- IP 65
	Explosion protection	- II 2 G EEx ib IIC T6

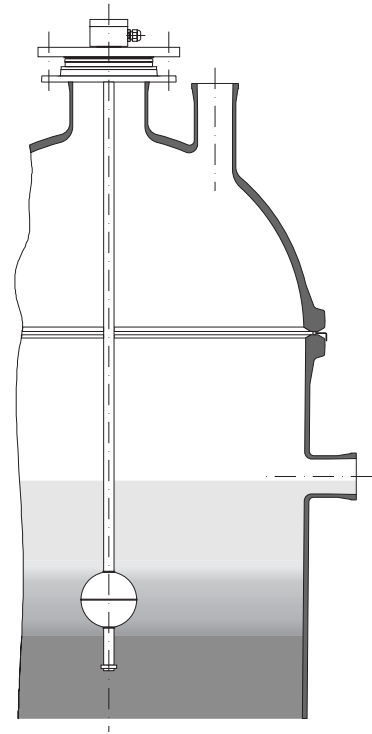

## PNEUMATIC INTERFACE MEASUREMENT

Float type measuring instruments are used for measuring the interface between two liquids in horizontal separators and extraction columns. The measurement signal is converted by means of magnetic transmission from a pneumatic proportional controller into a 0.2 to 1 bar output signal. These floats can be installed either from the side or from above in a branch with a minimum size of DN 80. The output signal at the float's midpoint is 0.6 bar. The normal control range is +15mm/-15mm and this can be extended by lengthening the stem. The density of the heavy phase must be at least 0.70 kg/dm<sup>3</sup>.

If the output signal is not switched directly to a pneumatic control valve, the signal can be converted via a P/I converter (option) to 4-20 mA and processed in an electrical controller.

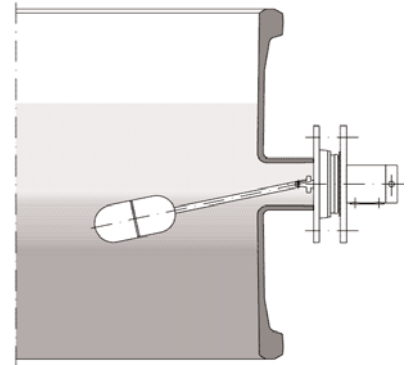

### Technical data

Supply	Instrument air	- 1.4 bar
	Control connection	- G 1/8
	Ambient temperature	- 0 to +80 °C
Materials	Connection housing	- Aluminium die casting
	Wetted	- Stainless steel or PTFE
Protection type	Housing	- IP 65