



QVF

PROCESS PLANT COMPONENTS



General

QVF structures are designed to support plant and other equipment comprising components exclusively or principally in borosilicate glass 3.3. Because of the special requirements resulting from the use of this material, structures are now available in the form of a proven modular system that not only meets standard requirements but also provides or facilitates solutions for problems of a very special nature.

Basically these structures consist of steel tubing in three different diameters which is connected using the appropriate fittings. As a result, the structures can not only be dismantled and reassembled whenever required but they can also be modified and added to quite easily. The modular system also includes components for establishing fixed points, supporting spherical and cylindrical vessels and horizontal cylindrical components plus a wide range of supports, to mention just the most important items. The result is an extremely flexible system.

The full range of components, which are available as standard in galvanised mild steel and to some extent in stainless steel, is described in this section. Special versions, which are available on request, are referred to under the respective product descriptions.

A detailed listing of all structure components by »Description« and »Catalogue Reference« can be found in the »Index«.

If any supports are required which you cannot find in this section, please contact us. Space does not permit the inclusion of every possible version in this catalogue.



The sizes of structure tubing and other fittings indicated for the various nominal sizes, shapes and configurations of glass components should be adhered to. If this is not possible due to special circumstances, please seek our advice on this and any other problems relating to structures.

Design of tubular structures

The diameter of structure tubing to be used plus minimum dimensions, i.e. width and depth of tubular structures are determined by the nominal size (cylindrical glass components) or diameter (spherical vessels) and the weight of the components they are designed to support. Details can be found in the table below and the related illustration.

If additional equipment or complicated pipework needs to be accommodated in a structure, appropriately larger sizes should be used.



The figures for DN 800 and DN 1000 cylindrical components and 500 litre nominal capacity spherical vessels only apply to installations with a low total weight. In all other cases, we recommend the use of a heavy duty fabricated base structure.

Structure dimensions for

Columns	Cylindrical vessels	Spherical vessels	Structure tube diameter	Structure dimension
DN	DN	Contents	mm	L
80	-	-	27	400
100	-	-	27	500
150	-	5, 10	42	600
200	-	20	42	700
300	450	50	42	800
450	600	100, 200	42	1000
450	600	100, 200	60	1100
600	-	-	42	1100
600	-	-	60	1400
800	800	-	60	1600/1510
1000	-	-	60	1930/1680

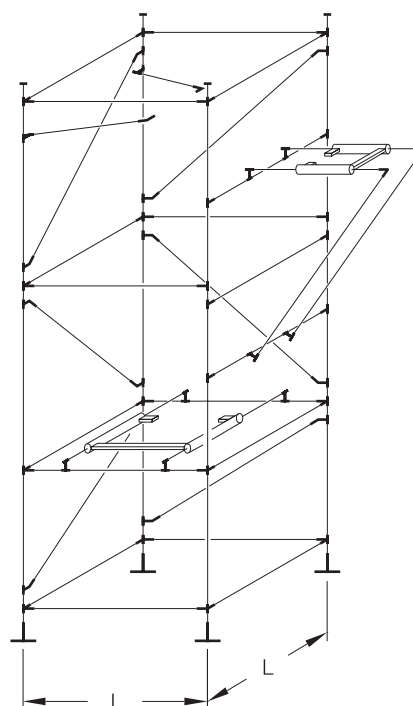

Support structures must be sufficiently rigid to prevent any bending of the individual tubes in excess of the permissible amount and the subsequent transfer of external stress to the glass components. This is achieved by incorporating additional bracing



For rigidity at least two adjacent sides of the structure should be provided with diagonal bracing. In addition, tall structures (e.g. for columns) should be braced back to existing structural steelwork or the walls of the building.

The establishment of fixed points is of particular importance. They are formed by combining a light duty support frame or heavy duty support frame with a coupling, a support plate or a support element (vessel holder, angle bracket, etc.). Fixed points have to carry the entire weight of a unit or column and should therefore, be located at the lowest point (in the case of a vessel holder) or lowest possible point (in the case of a support plate) in the installation.



Assembly of the glass components must always be started from the fixed point.

Glass units and their structures expand at different rates as a result of change in temperature. The unit must, therefore, be able to expand above the fixed point without restraint.

Guides giving lateral support must always be provided for units and columns.

If the overall height of the unit or column is fairly low this can be achieved by using two »KK50-5« or »KK50-7« structure fittings each with one of the set screws of a horizontally positioned coupling passing through them.

Above a certain height this is achieved with a light duty support frame which can also be used to support the weight of glass components during installation and maintenance work.

Guide elements should not be bolted rigidly to the unit or plant during operation.

Where supports are used in a structure for individual components or assemblies, these should be installed in such a way that the glass components are subject in the main to compressive forces. It has to be taken into consideration, that normally an additional fixed point is created at such points.



Glass components must be able to expand freely from a fixed point, therefore a bellows is generally fitted between two fixed points.

If there is the risk of vibration generated in the vicinity of glass units being transferred to the tubular structure, appropriate preventive measures should be taken.

The structure components described on pages 10.5 to 10.8 can also be used to support platforms and walkways for the use of plant operators and maintenance staff. They are connected directly to the plant support structure which results in a particularly compact design. The decking of these platforms and walkways is in the form of grids or embossed metal sheets.

Supporting Horizontal Pipeline

Both horizontal and vertical pipelines must be supported at certain intervals to avoid subjecting them to additional stress due to bending or lateral movement (e.g. on either side of bellows). The recommended spacing of horizontal pipeline supports as a function of nominal size is indicated in the table below.

Pipeline DN	Maximum spacing of supports	L in mm for	
		Gas	Liquid
		$\rho = 1$	$\rho = 1,8$
15	1500	1500	1000
25	2000	2000	1500
40	2500	2000	1500
50	2500	2000	1500
80	3000	2000	1500
100	3000	2500	2000
150	3000	2000	2000
200	3000	2000	1500
300	3000	2000	1500

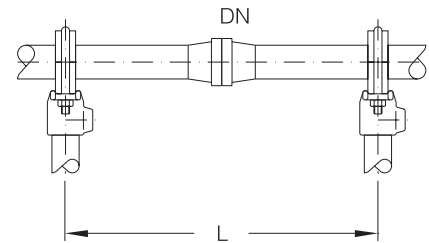

Clean Room Design

Stainless steel structure, support and coupling components can be supplied for use in applications where clean room conditions apply (see also Section 9 »Couplings«).

We would be happy to advise you on the requirements applicable in each particular case using the guidelines we have drawn up for the design of complete tubular structures for use under clean room conditions.

STRUCTURE TUBING

This tubing is used in conjunction with the structure fittings described on pages 10.6 to 10.8 to form the basis of structures to support borosilicate glass 3.3. plant. Structure tubing is available in three sizes and can be supplied in galvanised mild steel or stainless steel. This is to take into account the fact that glass is used in areas where various degrees of corrosive atmosphere are encountered.

As it is important that the structure tubing should not bow by more than 2 mm, the maximum permissible free length of the tubing is dependent on the load it is carrying. This can be calculated, at a fixed point for example, as the sum of the weights of support frames, glass components including couplings and liquid content. The number of support points should also be taken into account. Further information can be found in the illustration alongside and the diagram below.

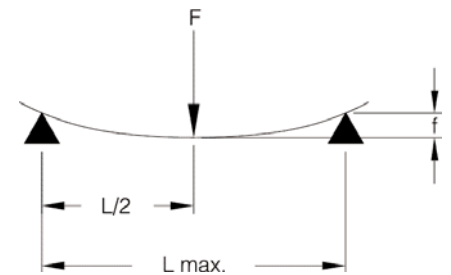
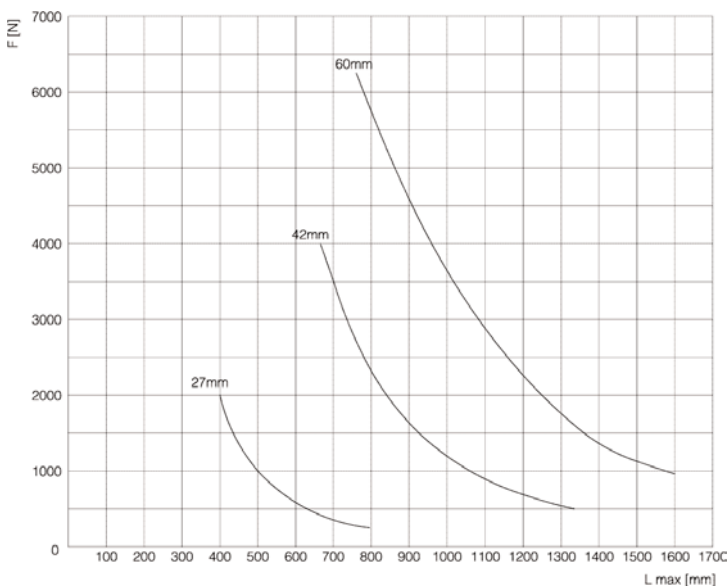

Permissible structure tubing load as a function of unsupported length



If individual lengths of tubing are required cut to a specific length, please add the length (in mm) to the catalogue reference.

For tubular structures that are to be installed in clean rooms, we can also supply stainless steel tubes with a ground finish on request. The catalogue reference is then for example: »M-RO7E/..«.

The structure components described below and on pages 10.6 to 10.8 can also be used to support platforms for the use of plant operators and maintenance staff. They are connected direct to the plant support structure which results in a particularly compact design. The decking of these platforms is in the form of grids or embossed metal sheets.

D	Fitting size	L	Reference Galvanised	Reference Stainless steel	Reference Ground
27	5	variable	RO5/....	-	M-RO5E/....
42	7		RO7/....	-	M-RO7E/....
60	9		RO9/....	RO9E/....	-
75	10		RO10/....	-	-

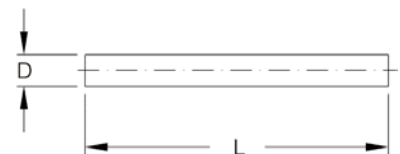

STRUCTURE FITTINGS

Closed sided fittings are used principally in conjunction with structure tubing to build complete structures where the design has been fixed prior to installation together with the necessary support frames, brackets, diagonal bracing and supports. In such cases subsequent modifications can only be carried out on a restricted basis.

If it is expected at the time of the original installation that extensive modification may be required or will have to be carried out subsequently, we recommend that the use of open sided structure fittings be considered. They are also ideal for items added to the structure at a later stage (e.g. support frames) or extra fittings (e.g. brackets).

We can supply a comprehensive range of closed and open sided structure fittings to cater for the various applications and the many different requirements encountered in practice. The finishes available are galvanised (catalogue reference »KK..« and »KKO..«), coated blue (catalogue reference »M-KK..« and »M-KKO..«) and to some extent stainless steel (catalogue reference »KK.. E« and »KKO..E«). Further details, including details of the various possible uses of the individual fittings and the necessary accessories, can be found in the tables on pages 10.7 and 10.8.



If type »KKO..« structure fittings are fixed to horizontal tubes, they should always be located on top of the tube, so that a closed assembly is ensured.

The structure components described on pages 10.5 to 10.8 can also be used to support platforms for the use of plant operators and maintenance staff. They are connected directly to the plant support structure which results in a particularly compact design. The decking of these platforms is in the form of grids or embossed metal sheets.

STRUCTURE FITTINGS

Closed Sided Fittings

Purpose	For tube diam.	Reference	Reference coated blue	Reference Stainless steel	
Single tube socket	27 mm	KK10-5	M-KK10-5	-	
	42 mm	KK10-7	M-KK10-7	KK10-7E	
	60 mm	KK10-9	M-KK10-9	-	
Tube coupler (to lengthen tubes)	27 mm	KK14-5	M-KK14-5	-	
	42 mm	KK14-7	M-KK14-7	-	
	60 mm	KK14-9	M-KK14-9	-	
90° Elbow fitting	27 mm	KK15-5	M-KK15-5	-	
	42 mm	KK15-7	M-KK15-7	-	
	60 mm	KK15-9	M-KK15-9	-	
Corner fitting	27 mm	KK21-5	M-KK21-5	-	
	42 mm	KK21-7	M-KK21-7	KK21-7E	
	60 mm	KK21-9	M-KK21-9	-	
Side fitting	27 mm	KK26-5	M-KK26-5	-	
	42 mm	KK26-7	M-KK26-7	KK26-7E	
	60 mm	KK26-9	M-KK26-9	-	
For tee connections	27 mm	KK35-5	M-KK35-5	-	
	42 mm	KK35-7	M-KK35-7	KK35-7E	
	60 mm	KK35-9	M-KK35-9	-	
For cross connections	27 mm	KK40-5	M-KK40-5	-	
	42 mm	KK40-7	M-KK40-7	KK40-7E	
	60 mm	KK40-9	M-KK40-9	-	
For fitting removable tubes	27 mm	KK45-5	M-KK45-5	-	
	42 mm	KK45-7	M-KK45-7	KK45-7E	
	60 mm	KK45-9	M-KK45-9	-	
For diagonals in conjunction with KKO50-7 and KKO50-9 respectively	27 mm	KK49-5	M-KK49-5	KK49-5E	
	42 mm	KK49-7	M-KK49-7	-	
	60 mm	-	-	-	
For supporting flanges in conjunction with KKO45-75 and KKO45-95 respectively (see p. 10.8)	27 mm	KK50-5	M-KK50-5	-	
	42 mm	KK50-7	M-KK50-7	-	
	60 mm	-	-	-	
Structure foot	27 mm	KK62-5	M-KK62-5	-	
	42 mm	KK62-7	M-KK62-7	KK62-7E	
	60 mm	KK62-9	M-KK62-9	-	
Replacement grub screw	27 mm	KK97-5	-	DI916-12x16-A2	
	42 mm	KK97-7	-	DI916-16x16-A2	
	60 mm	KK97-7	-	DI916-16x16-A2	
Replacement Allen key Steel (inches) Stainless steel (metric)	27 mm	KK99-5	-	6mm	
	42 mm	KK99-7	-	8mm	
	60 mm	KK99-7	-	8mm	
Plug for tube ends	27 mm	RP-5	-	-	
	42 mm	RP-7	-	-	
	60 mm	RP-9	-	-	
	75 mm	RP-10	-	-	

STRUCTURES & SUPPORTS

STRUCTURE FITTINGS

Open Sided Fittings

Purpose	For tube diam.	Reference	Reference coated blue	Reference Stainless steel	
For addition of single tubes	27 mm	-	-	-	
	42 mm	KKO10-7	M-KKO10-7	-	
	60 mm	-	-	-	
For fitting removable 75 mm diam. tubes with support frames	-	KKO17-109	M-KKO17-109	-	
	RRDN600//2.5 75 mm diam. tube	-	-	-	
Corner socket for addition of extra tubes	27 mm	-	-	-	
	42 mm	KKO21-7	M-KKO21-7	-	
	60 mm	-	-	-	
Corner socket for addition of extra tubes	27 mm	-	-	-	
	42 mm	KKO26-7	M-KKO26-7	-	
	60 mm	-	-	-	
Corner socket for addition of extra tubes	27 mm	-	-	-	
	42 mm	KKO35-7	M-KKO35-7	-	
	60 mm	-	-	-	
For addition of removable 27 mm diam. tubes, support frames and brackets	27 mm	-	-	-	
	42 mm	KKO45-75	M-KKO45-75	KKO45-75E	
	60 mm	KKO45-95	M-KKO45-95	-	
For support frames	27 mm	KKO45-5	M-KKO45-5	-	
	42 mm	KKO45-7	M-KKO45-7	-	
	60 mm	KKO45-97	M-KKO45-97	-	
For diagonals in conjunction with fittings KK49-7 and KK49-5	27 mm	KKO50-5	M-KKO50-5	KKO50-5E	
	42 mm	KKO50-7	M-KKO50-7	KKO50-7E	
	60 mm	KKO50-9	M-KKO50-9	-	
Replacement grub screw (metric)	27 mm	DI916-12x16-ST	-	DI916-12x16-A2	
	42 mm	DI916-16x20-ST	-	DI916-16x20-A2	
	60 mm	DI916-16x20-ST	-	DI916-16x20-A2	
Replacement Allen key	27 mm	6mm	-	6mm	
	42 mm	8mm	-	8mm	
	60 mm	8mm	-	8mm	

REDUCING FITTINGS

If it is necessary for design or technical reasons to reduce the diameter of the tubing used in a support structure, the reducing fittings listed below can be used. In principle, these should be handled in the same way as »KK14.. « sleeve couplings.

D1	D2	D3	D4	L	L1	L2	Reference Galvanised	Reference Stainless steel
42	27	70	48	100	51	39	RC75	RC75E
60	42	90	70	125	62	51	RC97	RC97E

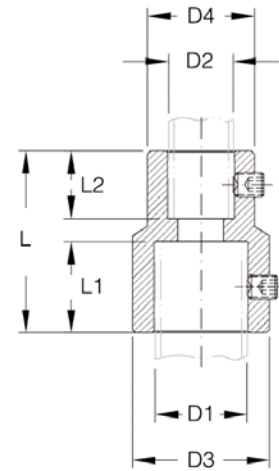

STRUCTURE BUSHES

One of the best ways to fix supports in structures is to use screwed rod. This is connected directly to the tubular structure using structure fittings or, where heavy components are involved, using structure bushes as well. In addition, structure bushes are also required to fix support brackets and support saddles (see pages 10.14 and 10.15) in the structure.

In special cases, it is also possible to fix vessel holders and support rings (see pages 10.13 and 10.14) and column support plates (see page 10.12) directly to the tubular structure using structure bushes. There is then no need to use a support frame (see page 10.11).

For tube	M	L	H	Reference Stainless steel
27	8	57	50	RRM8-5
27	10	78	52	RRM10-5
42	8	57	68	RRM8-7
42	10	78	69	RRM10-7
42	12	75	71	RRM12-7
42	16	95	74	RRM16-7
60	12	75	95	RRM12-9
60	16	95	98	RRM16-9

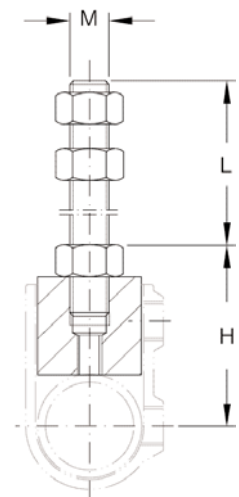

SUPPORT STOOLS

Because of the considerably greater weight to be supported when tall units and columns in the DN 800 and DN 1000 nominal sizes are involved, the design of the fixed point must be more substantial than in the smaller nominal sizes. The ideal solution is a heavy duty support stool which can be combined with a fixed point flange (see section 9 »Couplings«) and on which the 60mm tubular structure required is erected. A typical application is shown in the illustration alongside.



Plant and columns must be able to expand without restriction from a fixed point, therefore a bellows is generally fitted between two fixed points.

We can also supply suitable designs for special sizes and other nominal sizes on request.

To suit DN	L	L1	L2	L3	L4	L5	K	n x d	Reference
800	variable	183	1600	1510	1740	1650	1050	4 x 18	UBD800/2
1000	variable	184	1930	1680	2070	1820	1220	4 x 18	UBD1000/2

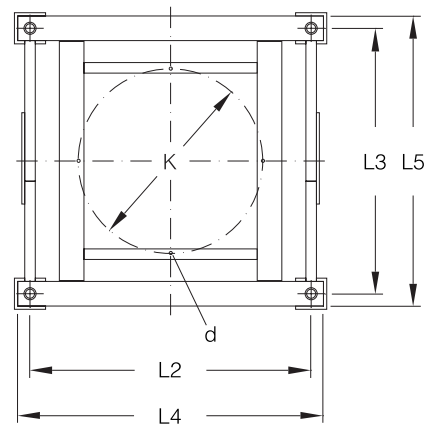
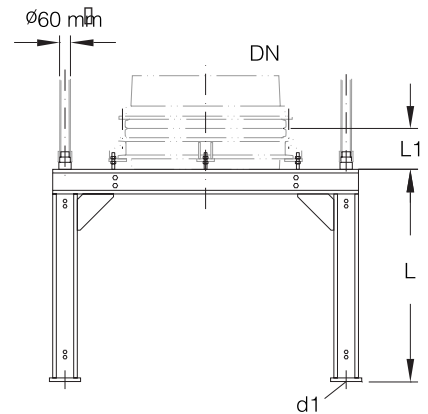

SUPPORT FRAMES

These frames are used in the DN80 to DN600 range of nominal sizes as a base element for a fixed point and are installed horizontally using tubes and fittings on a framework in the structure. Cylindrical components are then fixed directly via a coupling (see pages 9.4 to 9.10) or indirectly via support plates (see page 10.12). Spherical and cylindrical vessels are supported indirectly via vessel holders or support rings (see pages 10.13 and 10.14). These elements are connected to the support frames using screwed rod which, for stability reasons, should be as short as possible. They are also used to align the couplings or structure elements supported on the support frames.

Support frames are supplied in galvanised finish or stainless steel and have a QVF PCD. The material required for fixing the support frames and the screwed rod required (see above) are included in the supply.

Information about using these support frames with couplings, vessel holders, etc. can be found in the respective product description.



Plant and columns must be able to expand without restriction from a fixed point, therefore a bellows is generally fitted between two fixed points.

Plant and columns must always be provided with lateral support. Above a certain height, support frames should be used for this purpose.

DN	L	L1	L2	L3	K	n x d	Tube diam	Reference Galvanised	Reference Stainless steel
80	92	51	195	150	133	3 x M8	27	RRD80	RRD80E
100	107	63	235	200	178	3 x M8	27	RRD100	RRD100E
150	145	83	300	200	254	3 x M10	27	RRD150	RRD150E
150	147	88	300	200	254	3 x M10	42	RRD150/1.25	RRD150/1.25E
200	168	120	305	200	280-295	3 x M8/M10	42	RRD200	RRD200E
300	218	119	436	210	395-400	3 x M8/M12	42	RRD300	RRD300E
400	273	115	550	270	495	3 x M12	42	RRDN400	RRDN400E
400	273	115	575	340	495	3 x M12	60	RRDN400/2	RRDN400/2E
450	313	133	640	280	585	3 x M12	42	RRDN450	RRDN450E
450	313	133	660	340	585	3 x M12	60	RRDN450/2	RRDN450/2E
600	379	226	700	330	710	3 x M12	42	RRDN600	RRDN600E
600	375	230	755	410	710	3 x M12	75	RRDN600/2.5	RRDN600/2.5E

Typical applications

Reference	Columns DN Fig. A	Support rings Fig. C	Vessel supports Fig. C	Support plates Fig. B
RRD80	80	-	-	-
RRD100	100	-	-	CTF80
RRD150	150	VRSE5, VRSE10	-	CTF100
RRD150/1.25	150	VRSE5, VRSE10	-	CTF100
RRD200	200	VRSE20,	VHZ300, VHZE300	CTF150
RRD300	300	-	VHS50, VHSE50 VHS100, VHSE100 VHZ450, VHZE450	CTF200
RRDN400	-	-	-	CTF300
RRDN400/2	-	-	-	CTF300
RRDN450	450	(CCS450RRD or	CSS450RRD)	-
RRDN450/2	450	-	VHS200, VHSE200	-
RRDN600	600	-	-	CTFN450
RRDN600/2.5	600	-	-	CTFN450

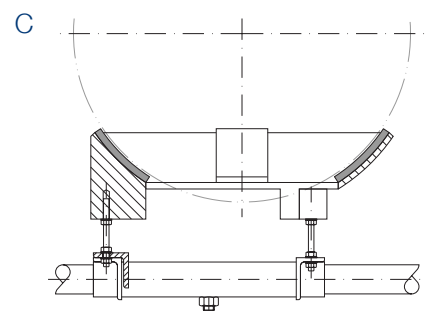
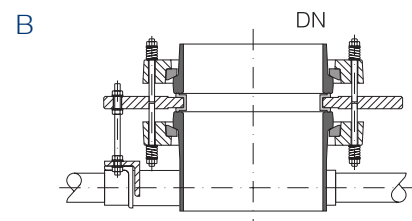
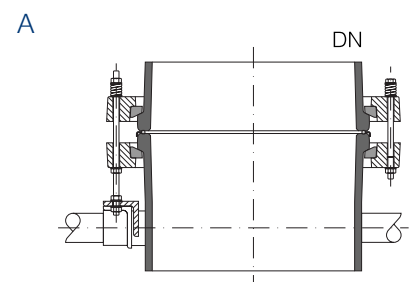
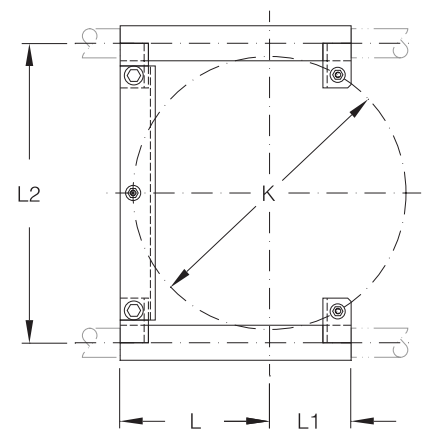
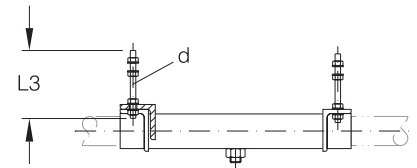

SUPPORT PLATES

Indirectly installing cylindrical borosilicate glass 3.3 components on support frames using support plates offers a significant benefit compared to the combination of a coupling and light duty support frame: the glass components above and below can be installed and dismantled independently from each other. As the PCD is different, the support flange remains firmly connected to the support frame or structure during such work.

Another benefit of the support plate is that the weight of the glass components supported on it only results in compressive stress therefore as a rule there is no need to compensate for this weight.

Support plates consist of a steel ring, which is primed and protected against corrosion by an epoxy resin paint, and a high grade PTFE sheath. The complete assembly also includes the coupling components for the glass such as bolts, nuts, washers, and compression springs but no flanges. As the support plate incorporates a sealing bead on both sides, no additional PTFE gaskets are required.

The support plate metal rings can also be supplied in stainless steel on request.

DN	D	L	K	K1	n x d1	n x d2	Type	To suit support frame	Reference
80	205	18	133	178	6 x M8	3 x 9	A	RRD100	CTF80
100	290	18	178	254	6 x M8	3 x 11	A	RRD150 RRD150/1.25	CTF100
150	350	20	254	295	6 x M10	3 x 11	A	RRD200	CTF150
200	430	22	295	400	8 x M8	3 x 14	A	RRD300	CTF200
300	530	22	400	495	12 x M8	3 x 14	A	RRDN400 RRDN400/2	CTF300
450	760	27	585	710	16 x M8	3 x M12	B	RRDN600 RRDN600/2.5	CTFN450
600	900	33	710	850	20 x M12	3 x M16	B	U-section	CTFN600

A

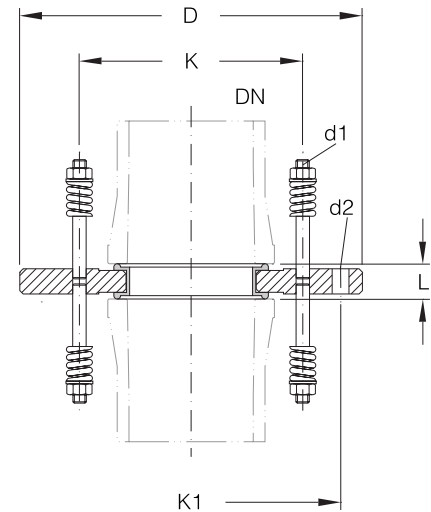

B

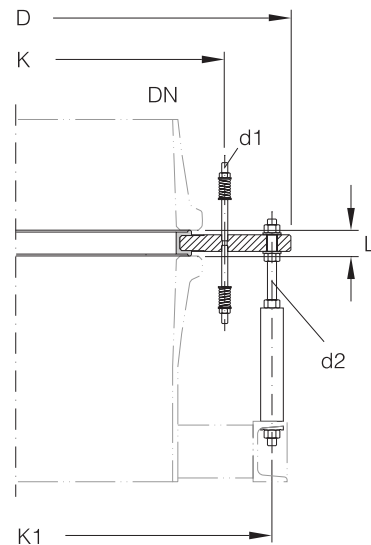

VESSEL HOLDERS

These vessel holders are used to support borosilicate glass 3.3 spherical and cylindrical vessels with a nominal capacity of 50 litres and above. The lining of the holder is specially shaped to fit the outside of the particular vessel. The metal casing of the holder is cast aluminium or steel (»VHS500« only) primed and epoxy resin painted to protect it against corrosion, or stainless steel respectively. All vessel holders have a QVF PCD.

Spherical Vessel Holders

To suit Spherical vessel Capacity (l)	Support frame	D	H	L	L1	L2	L3	K	d1	Type	Reference	Reference Stainless steel
50	RRD300	440	126	270	15	342	99	395	3 x M12	B	VHS50	VHSE50
100	RRD300	500	122	330	15	346	100	400	3 x M12	B	VHS100	VHSE100
200	RRDN450 u. 450/2	620	118	360	15	540	112	585	3 x M12	B	VHS200	VHSE200
500	-	980	267	505	12	566	330	800	4 x 18	C	VHS500	VHSE500

Cylindrical Vessel Holders

To suit: Cylindrical vessel DN	Capacity (l)	Support frame	D	H	L	L1	L2	L3	K	d1	Type	Reference	Reference Stainless steel
150	5	RRD150 a. 150/1.25	-	-	68	10	220	64	254	3 x 11	A	-	VRZE150
200	10	RRD150 a. 150/1.25	-	-	88	10	220	64	254	3 x 11	A	-	VRZE200
300	20-50	RRD200	320	125	195	15	198	99	280	3 x M10	B	VHZ300	VHZE300
450	100-200	RRD300	440	125	240	15	342	99	395	3 x M12	B	VHZ450	VHZE450
600	300-400	RRD300	500	122	330	15	346	100	400	3 x M12	B	VHS100	VHSE100
800	500	RRDN600 a. 600/2.5	654	162	455	10	574	209	710	3 x 14	D	VHZ800	VHZE800
1000	750	RRDN600 a. 600/2.5	736	181	550	10	574	209	710	3 x 14	D	VHZ1000	VHZE1000

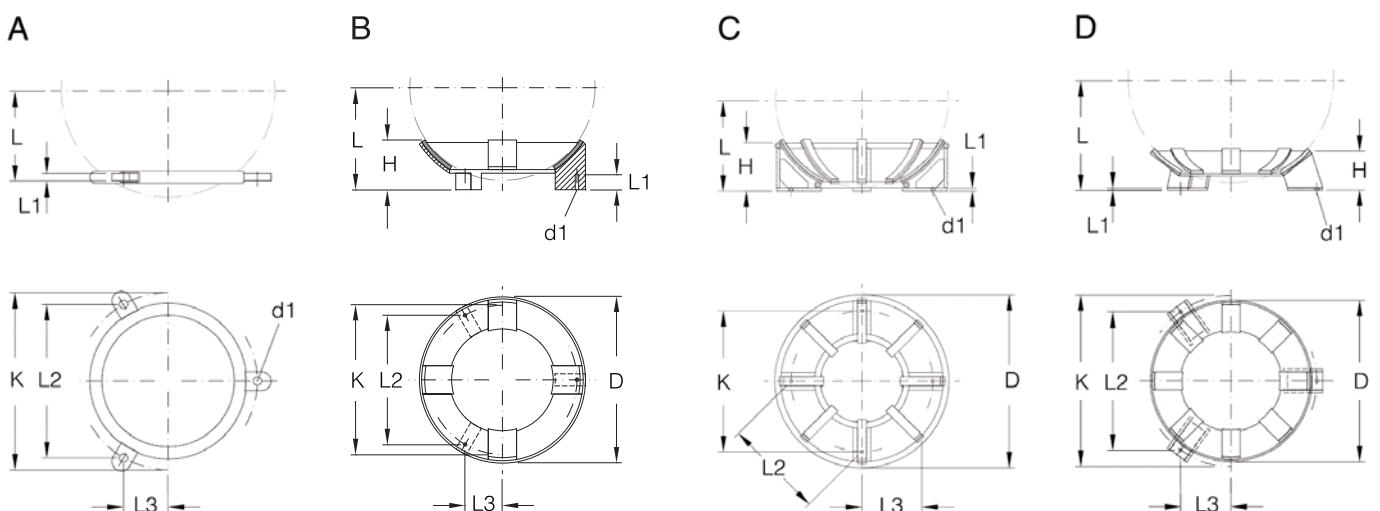

SPHERICAL VESSEL SUPPORT RINGS

This type of ring can be used to support borosilicate glass 3.3 spherical vessels up to a nominal capacity of 20 litres. They are stainless steel and are fitted with a close fitting silicon rubber sleeve. All support rings are drilled to a QVF PCD.

An alternative method of supporting these small spherical vessels in a tubular structure is by means of support brackets (see page 10.15). These are connected to the coupling on the top neck and this then forms the fixed point.

To suit		L	L1	L2	L3	K	n x d	Reference
Spherical vessel Capacity (l)	Support frame							
5	RRD150 or 150/1.25	78	10	220	64	254	3 x 11	VRSE5
10	RRD150 or 150/1.25	106	10	220	64	254	3 x 11	VRSE10
20	RRD200	138	10	209	104	295	3 x 9	VRSE20

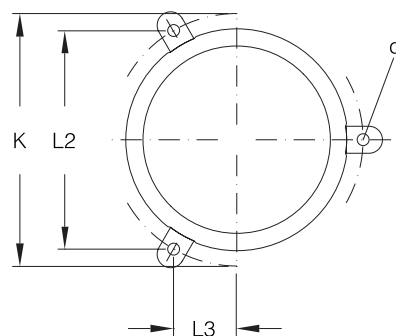
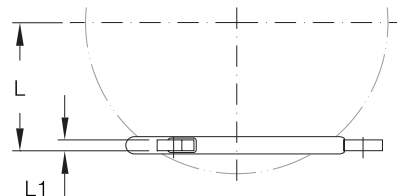

ANGLED SUPPORT BRACKETS

These brackets are used to support horizontal assemblies in the DN150 to DN300 nominal size range such as horizontal separators (see section 4 »Vessels & Stirrers«) or shell and tube heat exchangers (see section 5 »Heat Exchangers«). They are fitted to a coupling using longer set screws or fixed by means of »RRM..« structure bushes and closed or open structure fittings (see pages 10.6 to 10.9) to cross members.

Angled support brackets are supplied with either a galvanised finish or stainless steel as standard. The material required for connection to the tubular structure (see above) should be ordered separately.

To suit	K	H	L	L1	L2	d	Reference Galvanised	Reference Stainless steel
DN								
100	178	8	165	110	30	13	SUA100	SUA100E
150	225	9	208	200	40	14	SUA150	SUA150E
150	240	9	215	200	40	14	SUA150	SUA150E
150	254	9	208	200	40	14	SUA150	SUA150E
200	280	9	235	200	40	14	SUA150	SUA150E
200	295	9	243	200	40	14	SUA150	SUA150E
300	395	9	293	200	40	14	SUA150	SUA150E
300	400	9	295	200	40	14	SUA150	SUA150E

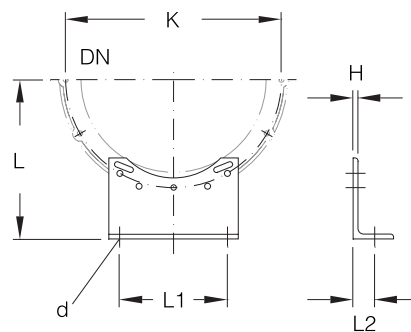

SUPPORT SADDLES

These support saddles with bracing strap are designed to support DN450 and DN600 assemblies such as horizontal separators (see Section 4 »Vessels & Stirrers«) in tubular structures. The lower part consists of a steel bar with segmented rubber lining and a profiled steel support frame. It is fixed by means of »RRM.« structure bushes and closed or open structure fittings (see pages 10.6 to 10.9) to horizontal structure tubes. The upper part is a rubber lined metal strap braced to the lower part by means of captive screwed rods and nuts.

Support saddles are supplied with either a galvanised finish or stainless steel as standard. The material required for connection to the tubular structure (see above) should be ordered separately.

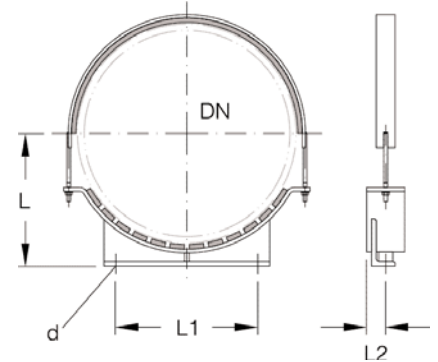

To suit DN	L	L1	L2	d	Reference Galvanised	Reference Stainless steel
450	280	300	40	18	SUS450	SUS450E
600	362	400	50	18	SUS600	SUS600E
800	475	630	50	18	SUS800	SUS800E

PIPELINE SUPPORT BRACKETS

These brackets are used in tubular support structures in conjunction with open sided structure fittings (see page 10.8), which guarantee the flexibility required in installation, and short lengths of structure tubing to provide a versatile support for borosilicate glass 3.3. components. They are supplied in a galvanised finish as standard.

As these brackets have the same PCD as the corresponding flange, they can be connected directly to a coupling. However, the standard set screws should be replaced by longer set screws or screwed rod which is available in all the normal diameters. Both should be at least 50 mm longer than the standard set screws to ensure an adequate setting range.



Fixing pipeline support brackets couplings nearly always creates a fixed point, from which glass components must be able to expand without restriction, therefore a bellows is generally fitted between two fixed points.

If long horizontal tubes are required to connect pipeline support brackets to the structure, these must be braced diagonally.

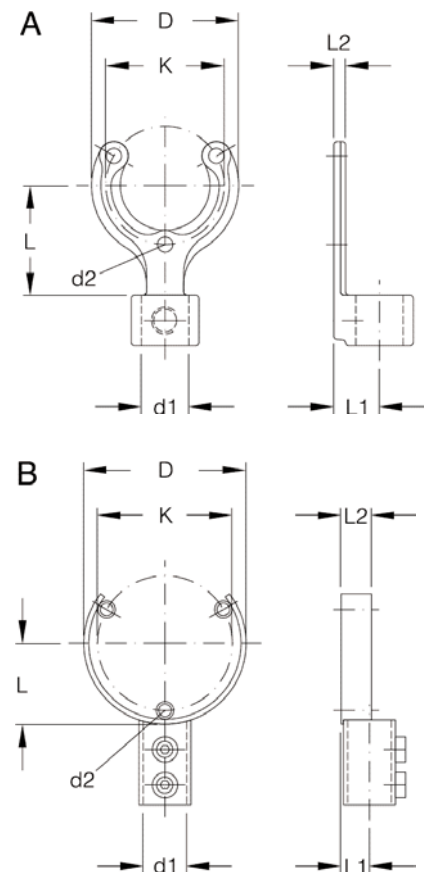

To suit DN	L	L1	L2	K	D	d1	d2	Type	Reference Galvanised	Reference Stainless steel
25	65	27	7,0	70	87	27	9	A	HK25	HK25E
40	65	27	7,0	86	103	27	9	A	HK40	HK40E
50	70	27	7,0	98	115	27	9	A	HK50	HK50E
80	100	30	16	133	156	27	9	A	HK80	HK80E
80	80	31	30	133	160	42	12,5	B	HK80/1.25	HK80/1.25E
100	103	31	30	178	205	42	12,5	B	HK100/1.25	HK100/1.25E
150	140	31	40	254	281	42	12,5	B	HK150/1.25	HK150/1.25E
200	164	31	50	295	328	42	11	B	HK200/1.25	HK200/1.25E
300	220	31	50	400	440	42	11	B	HK300/1.25	HK300/1.25E

PIPELINE SUPPORTS

These supports are used in conjunction with open sided structure fittings (please see page 10.8) which guarantee the flexibility required in installation, or structure feet and short lengths of structure tubing to support borosilicate glass 3.3 pipeline components in tubular structures and from walls. They consist of a two-piece rubber collar which grips the glass pipe firmly and a 'U' bolt fixed to a backplate. The latter has a socket so that it can be connected to the structure.

Pipeline supports are supplied with metal parts either in galvanised finish or stainless steel as standard. When correctly installed they do not constitute a fixed point, i.e. the weight of vertical pipelines should be taken up by other means, e.g. using pipeline support brackets.

When these supports are used for horizontal pipelines the recommended spacing indicated on page 10.4 must be adhered to. In the case of vertical pipeline, the distance between two supports should not exceed 5 meters.

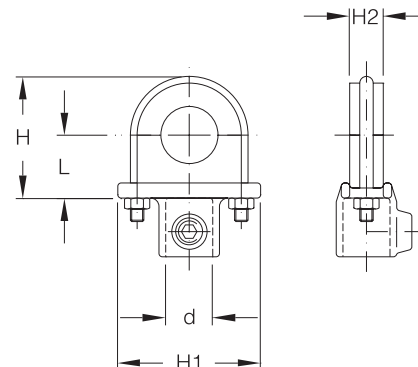

To suit DN	L	H	H1	H2	d	Reference Galvanised	Reference Stainless steel
15	38	73	85	20	28	HR15	HR15E
25	38	73	85	20	28	HR25	HR25E
40	56	103	110	20	28	HR40	HR40E
50	56	103	110	20	28	HR50	HR50E
80	81	155	165	20	28	HR80	HR80E
100	81	155	165	20	28	HR100	HR100E
150	127	255	270	40	28	HR150	HR150E
200	154	299	310	40	44	HR200	HR200E
300	189	374	390	40	44	HR300	HR300E

PIPE HANGERS

These hangers can be used to fix borosilicate glass 3.3 pipeline in structures and to walls. They comprise two parts, one having a captive nut welded to it into which M10 or M12 screwed rod can be screwed. A lock nut is also required. When used in tubular structures, the screwed rod is fixed with two nuts in closed sided («KK50-5« or «KK50-7«) or open sided («KKO50-5« or «KKO50-7«) structure fittings which guarantee the necessary flexibility in installation. A special type of support can be supplied for wall fixing.

Pipe hangers are supplied in either galvanised finish or stainless steel as standard with rubber to prevent direct contact with the glass components. When correctly installed they do not constitute a fixed point, i.e. the weight of vertical pipelines should be taken up by other means, e.g. using pipeline support brackets.

When these supports are used for horizontal pipelines the recommended spacing indicated on page 10.4 must be adhered to. In the case of vertical pipeline, the distance between two supports should not exceed 5 meters.

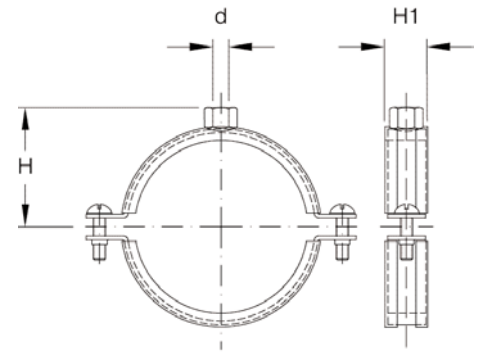

Structure fittings type «KK50-5« and «KKO50-5« require drilling out from 11 to 13 mm diameter.

To suit DN	H	H1	d	Reference Galvanised	Reference Stainless steel
15	36	23	M10	HS15	HS15E
25	42	23	M10	HS25	HS25E
40	48	34	M12	HS40	HS40E
50	54	34	M12	HS50	HS50E
80	69	34	M12	HS80	HS80E
100	83	34	M12	HS100	HS100E
150	110	46	M12	HS150	HS150E
200	137	46	M12	HS200	HS200E
300	183	46	M12	HS300	HS300E

SAFETY SCREENS

Fitting support structures with safety screens meets two safety requirements at the same time: operating personnel are protected from any hazards that may arise from possible breakages and the units are protected against mechanical damage arising from external sources.

Safety screens consist of sheets of medium flexibility transparent PVC with high resistance to abrasion. To ensure good lateral stability, they have galvanised metal strips bolted on both sides at the top and bottom. Hooks are also fitted to the top edge to enable the safety screen to be suspended from the structure.

Safety screens are 5 mm thick. Up to a width of 1100 mm they are supplied in one piece as standard. Larger screens are two-piece with an overlap. The maximum possible length is 6 metres.

Safety screens can also be supplied on request in special widths, in articulated form or, where the complete structure requires screening, with sliding panels or with covered hand holes on the operating side.



When ordering, the required height in mm should be added to the catalogue reference.

We can also supply rigid PVC safety screens with antistatic coating, i.e. electrically conductive surface, on request. These are suitable for use in areas where electrostatic loading is possible. The surface resistance is 10^9 to $10^7 \Omega$.

Structure dimension L	L1	Type	H	H1	H2	Structure tube diameter	Reference
400	-	A		55	15	27	SVH400/..
500	-	A		55	15	27	SVH500/..
600	-	A		75	15	42	SVH600/..
700	-	A		75	15	42	SVH700/..
800	-	A		75	15	42	SVH800/..
900	-	A	variable	75	15	42	SVH900/..
1000	-	A		75	15	42	SVH1000/..
1100	-	A		75	15	42	SVH1101/..
1100	-	A		105	15	60	SVH1102/..
1400	720	B		105	15	60	SVH1400/..
1510	775	B		105	15	60	SVH1510/..
1600	820	B		105	15	60	SVH1600/..
1680	860	B		105	15	60	SVH1680/..
1930	985	B		105	15	60	SVH1930/..

