



List of contents	Article No.	Description	Section/Page
<b>Technical Information</b>	-	General	1.2
	-	General	1.3
<b>Pipeline Components</b>	RO	KF Pipe sections	2.1
	RO	KF Pipe sections	2.2
	RO	KF Spacers	2.2
	RO.../U	KF Universal spacers	2.3
	RS	KF Reducers, concentric	2.4
	RU	KF Reducers, eccentric	2.5
	BO	KF Bends 90°	2.5
	BO	KF Bends 45°	2.6
	UB	KF U Bends	2.6
	HO	KF U Bends with bottom outlet	2.7
	KR	KF Cross pieces	2.7
	TS	KF Equal tee pieces	2.8
	TS	KF Unequal tee pieces	2.8
	BL	KF Closures	2.9
	OL	KF Straight hose connectors	2.9
	OL.../W	KF Hose connectors 90°	2.10
<b>Valves &amp; Filters</b>	-	General	3.1
	VSN	KF Straight through valves	3.2
	VEN	KF Angle valves	3.2
	VSN.../OL	KF Drain valves	3.3
	VEN.../LUE	KF Vent valves	3.3
	VDN	Loading valves	3.4
	VKN	KF Ball type non-return valves	3.4
	VEN.../SP	Angle valves with Samson actuator	3.5
	VEN.../KP	Angle valves with Flowserve-Kammer actuator	3.5
	-	KF Control valves, general	3.6
	VEN.../RH/..	KF Hand control valves	3.6
	-	KF Pneumatically actuated control valves, general	3.7
	VEN.../RSP/..	KF Control valves with Samson actuator	3.7
	VEN.../RKP/..	KF Control valves with Flowserve-Kammer actuator	3.8
	VEN.../FS	KF Pressure relief valves	3.9
	KH/G...	KF Ball Valves with borosilicate glass 3.3 body	3.10
	KHK	KF Compact ball valves with GGG/PFA body	3.10
	-	KF Pneumatically actuated ball valves, general	3.11
	KHPN/G...	KF Ball Valves with borosilicate glass 3.3 body	3.11
KHKP	KF Compact ball valves with GGG/PFA body	3.12	
<b>Couplings</b>	-	General	9.1
	SVED.../K	KF Couplings with plastic flanges	9.2
	SVER.../S	KF Couplings with silumin flanges	9.3
	SVER.../S/H	KF Couplings with silumin flange rings and steel spiral inserts	9.3
	SCHD.../K	KF Plastic backing flanges	9.4
	SCHE.../S	KF Silumin backing flanges	9.4
	BEIL.../K	KF Plastic inserts	9.5
	BEIL.../S + UNLA	Stainless steel spiral inserts	9.5
	BEIL.../AS	KF Silumin inserts with rubber/fibreglass layer	9.6
	DFSS	Compression springs	9.6
	RWSS	Reducing washers for flanges to EN 1092, PN 10	9.7
	RWSS	Reducing washers for flanges to ANSI, class 150	9.7
	DICH.../TG	PTFE 'O' ring gaskets	9.7
	-	Permissible operating conditions for FALD.../UF.. bellows	9.8
	FALD.../UF	Bellows for double-sided connection to glass pipe ends and EN connections as per EN 1092, PN 10	9.8
	FALDA.../UF	Adapters for connecting glass	9.9
	FVED.../UF/K	Bellows for connecting glass and ANSI, class 150	9.9
	DICHN.../TE	Metal/PTFE spacers	9.10
	WELN	KF Product hoses	9.10
	CPKFA	Adaptors KF to WPR	9.11
<b>Structures &amp; Supports</b>	GEGAN	Universal support brackets for EN/ANSI and silumin pitch circles	10.1
	GEGAN	Support brackets for EN1092, PN10 flange connections	10.1
	GEGAS	Support brackets for flange connections with cilium flange rings	10.1
	GETR.../U	Support ring	10.2

## GENERAL

Pipelines, apparatus and systems made of borosilicate glass 3.3 which carry the CE mark, are manufactured and quality monitored in compliance with the Pressure Equipment Directive (97/23/EC). At the same time, the chemical/physical material characteristics of borosilicate glass 3.3 and the design of glass components are subject to national and international standards.

The type of flange for glass parts is not standardised, but is determined according to the user's technical demands. Whilst, for instance, a flat safety flange is excellently suited to GMP system engineering due to its construction with little dead space, a ball and socket system is highly valued for its flexibility.

For this reason, QVF has included the ball and socket pipeline system from the former Schott catalogue 6076, in this supplement, to the WPR catalogue, as the "KF pipeline system" and is manufacturing it with state-of-the-art technology and in line with the aforementioned standards and directives as an alternative coupling system for glass system engineering.

The KF pipeline system has therefore not only been given the CE mark, but certification for compliance with the Clean Air Act has also been provided for the valves and couplings. Accuracy of manufacturing, storage and quality control all correspond to WPR 2002.

## REFERENCE NUMBERS

The Schott KF system from catalogue 6076 is a common coupling system in the fields of industry and research. The reference numbers listed in this catalogue supplement therefore correspond to those from catalogue 6076. In those instances in which the technical properties have been changed, an "N" (new) has been added to the reference number.

Whilst the parts made purely of glass are listed identically to listings in catalogue 6076, for hand-operated valves, for instance, the important dimensions for connection compatibility are identical, but internal parts have been given a second seal and a cone as standard to improve regulation. An "N" has been added to the order number for these valves (e.g. VEN 25).

## MATERIAL PROPERTIES/OPERATING DATA

The "KF pipeline system" is a supplement to the QVF catalogue "Process Plant Components", also known as "WPR 2002". Thus, the information given in the catalogue on

- borosilicate glass 3.3, chemical, physical properties
- permitted operating conditions
- dimensioning of components
- labelling of components
- danger analysis and potential hazards

also applies to the "KF pipeline system". You will find the operating data for the valves in the valves section of this supplement. Any variations are listed for each individual article as applicable.



## KF PIPE ENDS

The designation KF was derived from Schott's German name for the ball and socket system ("Kugel-Flansch") and comprises spherically ground sealing surfaces and a shoulder flange for force transmission. In this catalogue, ball pipe ends are all labelled with the code digit 1 and socket pipe ends with code digit 2. Possible variants are also shown in the drawings.

You will find the main KF pipe end dimensions in the following table.

DN	D1	D2	D3	D4 <sup>1)</sup>	R
15	14-16	30	23	14-16	18
25	23-26	44	34	22,5-25,5	25
40	38-42	62	51	38,5-41,5	40
50	47,5-52,5	76	63	48,5-51,5	50
80	80,5-82,5	110	96	77,5-82,5	80
100	100-102	130	116	102-108	100
150	152,5-154,5	184	169	147-155	150
200	202-204	233	220	196-206	200
300	299-301	338	321	292,5-305,5	300

<sup>1)</sup> The dimensions provided refer to the internal diameter of straight standard pipes.

The internal diameter of fittings and melting areas may vary.

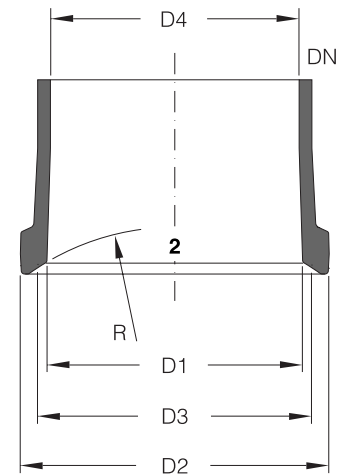
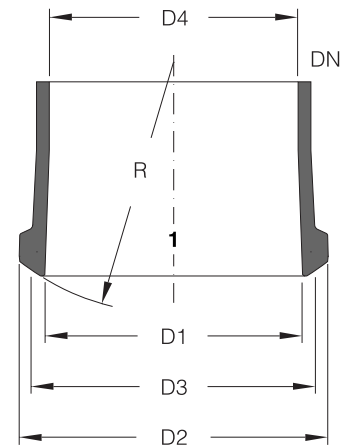

## ALIGNMENT OF KF COUPLINGS

Before the final sealing force is applied, glass parts can be aligned at an angle to each other so that horizontal pipelines can be laid with a gradient  $\alpha$  without the need for additional components.

The following table shows the maximum permitted angle of alignment by nominal diameter for a pipe with a length of 1000 mm.

DN	15	25	40	50	80	100	150	200	300
X (mm)	87	52	52	52	52	34	26	17	17
$\alpha^\circ$	5	3	3	3	3	2	1,5	1	1

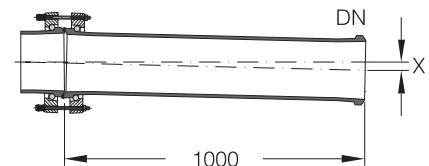

## CONNECTION TO OTHER MATERIALS AND FLANGE SYSTEMS

Connections can be made to pipelines made of other materials either using bellows, in order to compensate for expansion and forces from external material, or using AMS or AFS glass adapters from WPR 2002. These adapters can also be used to connect to the flat safety flange. This connection can however, be established without the need for an additional glass part, using a CPKFA adaptor coupling.

## KF PIPE SECTIONS

	Reference	Reference	Reference
L	DN15	DN25	DN40
100	RO15/0100	RO25/0100	RO40/0100
125	RO15/0125	RO25/0125	RO40/0125
150	RO15/0150	RO25/0150	RO40/0150
175	RO15/0175	RO25/0175	RO40/0175
200	RO15/0200	RO25/0200	RO40/0200
300	RO15/0300	RO25/0300	RO40/0300
400	RO15/0400	RO25/0400	RO40/0400
500	RO15/0500	RO25/0500	RO40/0500
700	RO15/0700	RO25/0700	RO40/0700
1000	RO15/1000	RO25/1000	RO40/1000
1500	RO15/1500	RO25/1500	RO40/1500
2000	RO15/2000	RO25/2000	RO40/2000
3000	-	RO25/3000	RO40/3000

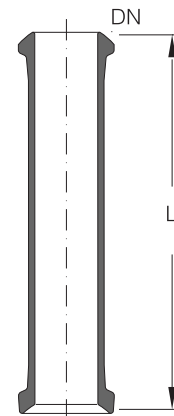

	Reference	Reference	Reference
L	DN50	DN80	DN100
100	RO50/0100	RO80/0100	RO100/0100
125	RO50/0125	RO80/0125	RO100/0125
150	RO50/0150	RO80/0150	RO100/0150
175	RO50/0175	RO80/0175	RO100/0175
200	RO50/0200	RO80/0200	RO100/0200
300	RO50/0300	RO80/0300	RO100/0300
400	RO50/0400	RO80/0400	RO100/0400
500	RO50/0500	RO80/0500	RO100/0500
700	RO50/0700	RO80/0700	RO100/0700
1000	RO50/1000	RO80/1000	RO100/1000
1500	RO50/1500	RO80/1500	RO100/1500
2000	RO50/2000	RO80/2000	RO100/2000
3000	RO50/3000	RO80/3000	RO100/3000

	Reference	Reference	Reference
L	DN150	DN200	DN300
150	RO150/0150	RO200/0150	-
175	RO150/0175	RO200/0175	-
200	RO150/0200	RO200/0200	RO300/0200
300	RO150/0300	RO200/0300	RO300/0300
400	RO150/0400	RO200/0400	RO300/0400
500	RO150/0500	RO200/0500	RO300/0500
700	RO150/0700	RO200/0700	RO300/0700
1000	RO150/1000	RO200/1000	RO300/1000
1500	RO150/1500	RO200/1500	RO300/1500
2000	RO150/2000	RO200/2000	RO300/2000
3000	RO150/3000	-	-

# PIPELINE COMPONENTS

## KF PIPE SECTIONS

Short pipes with the required combination of ball and socket are used to adjust to the various different types of flange.

DN	L	Reference	
		Type A	Type B
15	100	RO15/0100/11	RO15/0100/22
25	100	RO25/0100/11	RO25/0100/22
40	100	RO40/0100/11	RO40/0100/22
50	100	RO50/0100/11	RO50/0100/22
80	125	RO80/0125/11	RO80/0125/22
100	125	RO100/0125/11	RO100/0125/22
150	150	RO150/0150/11	RO150/0150/22
200	150	RO200/0150/11	RO200/0150/22
300	200	RO300/0200/11	RO300/0200/22

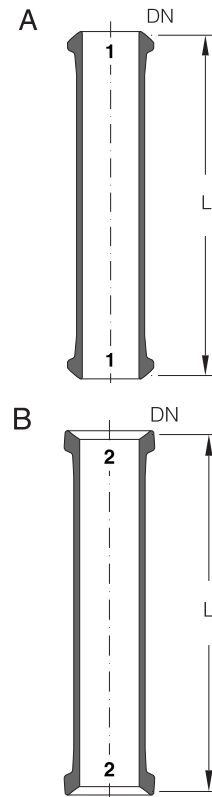

## KF SPACERS

KF spacers are used to adjust lengths and types of flanges. They are fastened in place between couplings using accordingly long screws.

DN	L	Reference		
		Type A	Type B	Type C
15	25	RO15/0025	RO15/0025/11	RO15/0025/22
15	50	RO15/0050	RO15/0050/11	RO15/0050/22
25	25	RO25/0025	RO25/0025/11	RO25/0025/22
25	50	RO25/0050	RO25/0050/11	RO25/0050/22
40	25	RO40/0025	RO40/0025/11	RO40/0025/22
40	50	RO40/0050	RO40/0050/11	RO40/0050/22
50	25	RO50/0025	RO50/0025/11	RO50/0025/22
50	50	RO50/0050	RO50/0050/11	RO50/0050/22
80	50	RO80/0050	RO80/0050/11	RO80/0050/22
100	50	RO100/0050	RO100/0050/11	RO100/0050/22
150	50	RO150/0050	RO150/0050/11	RO150/0050/22
200	50	RO200/0050	RO200/0050/11	RO200/0050/22

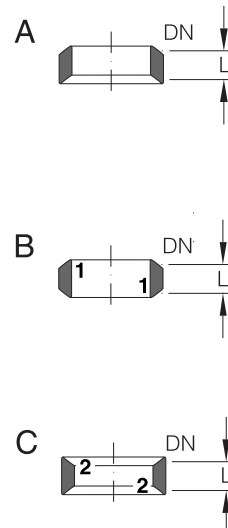

## KF UNIVERSAL SPACERS

These spacers can be used for all Schott pipe ends up to a nominal diameter of DN 150. They consist of a PTFE body with an external stainless steel support and can be used at an operating temperature of up to 120°C, up to the nominal pressures of the glass pipelines.



The universal spacer cannot be used in combination with the safety flat buttress end.

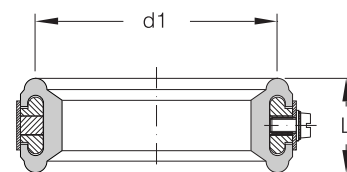

DN	L	d1	Reference
15	25	23	RO15/0025/U
25	25	35	RO25/0025/U
40	25	50	RO40/0025/U
50	25	64	RO50/0025/U
80	50	96	RO80/0050/U
100	50	116	RO100/0050/U
150	50	169	RO150/0050/U

## KF REDUCERS

### Concentric Reducers

Nominal diameter DN 80 and above with round bottom version (.../R).

DN	DN1	L	Reference
25	15	100	RS25/15/21
40	15	100	RS40/15/21
40	25	100	RS40/25/21
50	15	100	RS50/15/21
50	25	100	RS50/25/21
50	40	100	RS50/40/21
80	25	125	RS80/25/21/R
80	40	125	RS80/40/21/R
80	50	125	RS80/50/21/R
100	25	150	RS100/25/21/R
100	40	150	RS100/40/21/R
100	50	150	RS100/50/21/R
100	80	150	RS100/80/21/R
150	25	200	RS150/25/21/R
150	40	200	RS150/40/21/R
150	50	200	RS150/50/21/R
150	80	200	RS150/80/21/R
150	100	200	RS150/100/21/R
200	25	175	RS200/25/21/R
200	40	175	RS200/40/21/R
200	50	175	RS200/50/21/R
200	80	200	RS200/80/21/R
200	100	200	RS200/100/21/R
200	150	200	RS200/150/21/R
300	25	225	RS300/25/21/R
300	40	225	RS300/40/21/R
300	50	225	RS300/50/21/R
300	80	250	RS300/80/21/R
300	100	250	RS300/100/21/R
300	150	250	RS300/150/21/R
300	200	250	RS300/200/21/R

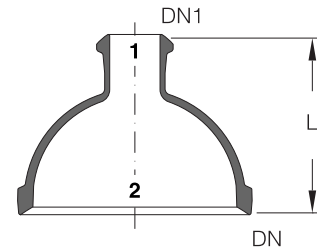

## KF REDUCERS, ECCENTRIC

Nominal diameter DN 80 and above with round bottom version (.../R).

DN	DN1	L	L1	Reference
50	25	100	13	RU50/25/21
80	25	125	25	RU80/25/21/R
100	25	150	35	RU100/25/21/R

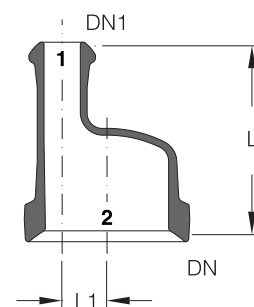

## KF BENDS 90°

DN	L	Reference
15	50	BO15/90
25	100	BO25/90
40	150	BO40/90
50	150	BO50/90
80	200	BO80/90
100	250	BO100/90
150	250	BO150/90
200	300	BO200/90
300	400	BO300/90

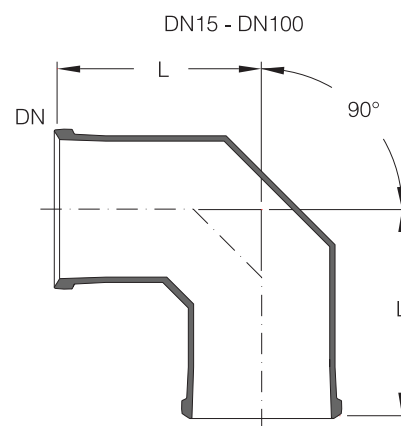
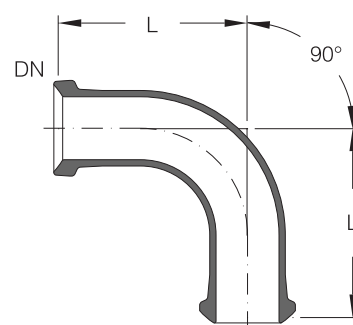

DN150 - DN300

# PIPELINE COMPONENTS

## KF BENDS 45°

DN	L	Reference
15	50	BO15/45
25	75	BO25/45
40	100	BO40/45
50	100	BO50/45
80	125	BO80/45
100	175	BO100/45
150	200	BO150/45
200	200	BO200/45
300	200	BO300/45

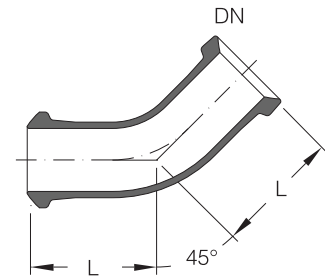

DN15 - DN100

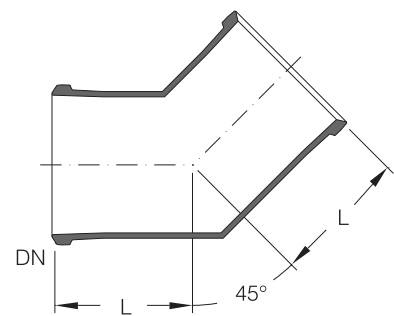

DN150 - DN300

## KF U BENDS

DN	L	L1	Reference
15	100	100	UB15
25	150	150	UB25
40	150	150	UB40
50	150	150	UB50
80	200	210	UB80
100	200	230	UB100

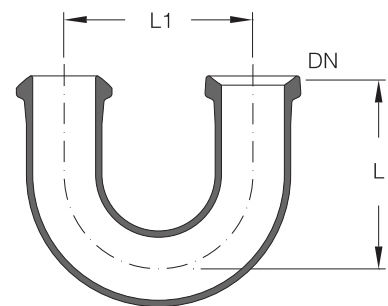

## KF U BENDS WITH BOTTOM OUTLET

DN	DN1	L	L1	L2	Reference
15	15	200	100	100	HO15/15
25	25	250	150	150	HO25/25
40	25	250	150	150	HO40/25
50	25	250	150	150	HO50/25
80	25	300	210	200	HO80/25
100	50	350	230	200	HO100/50

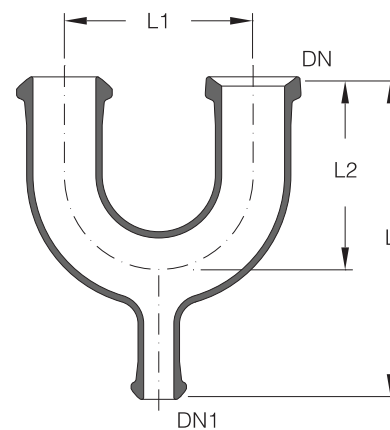

## KF CROSS PIECES

DN	L	Reference
15	50	KR15
25	100	KR25
40	150	KR40
50	150	KR50
80	200	KR80
100	250	KR100
150	250	KR150

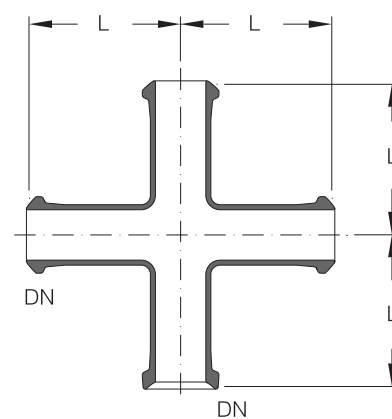

# PIPELINE COMPONENTS

## KF EQUAL TEE PIECES

DN	L	Reference	
		Type A	Type B
15	50	TS15/121	TS15/122
25	100	TS25/121	TS25/122
40	150	TS40/121	TS40/122
50	150	TS50/121	TS50/122
80	200	TS80/121	TS80/122
100	250	TS100/121	TS100/122
150	250	TS150/121	TS150/122
200	300	TS200/121	TS200/122
300	400	TS300/121	TS300/122

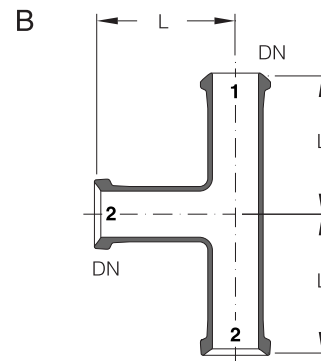
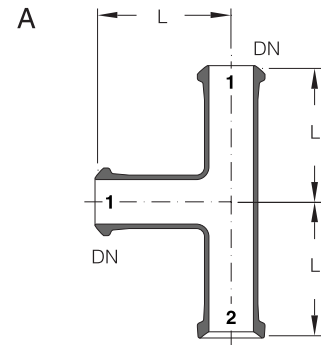

## KF UNEQUAL TEE PIECES

DN	DN1	L	L1	Reference
25	15	150	75	TS25/15/121
40	25	200	100	TS40/25/121
50	25	200	100	TS50/25/121
50	40	200	100	TS50/40/121
80	25	200	100	TS80/25/121
80	40	250	100	TS80/40/121
80	50	250	100	TS80/50/121
100	25	200	125	TS100/25/121
100	40	250	125	TS100/40/121
100	50	250	125	TS100/50/121
100	80	300	125	TS100/80/121
150	25	200	150	TS150/25/121
150	40	250	150	TS150/40/121
150	50	250	150	TS150/50/121
150	80	300	150	TS150/80/121
150	100	300	150	TS150/100/121
200	25	200	175	TS200/25/121
200	40	250	175	TS200/40/121
200	50	250	175	TS200/50/121
200	80	300	175	TS200/80/121
200	100	300	175	TS200/100/121
200	150	400	225	TS200/150/121
300	25	300	225	TS300/25/121
300	40	400	225	TS300/40/121
300	50	400	225	TS300/50/121
300	80	400	225	TS300/80/121
300	100	400	225	TS300/100/121
300	150	500	275	TS300/150/121
300	200	600	275	TS300/200/121

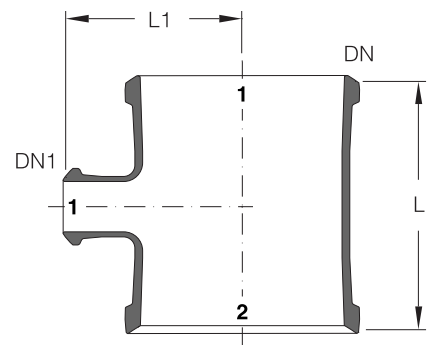

## KF CLOSURES

Nominal diameter DN 80 and above with round bottom version (.../R).

DN	L ca.	Reference	
		Type A	Type B
15	70	BL15/1	BL15/2
25	70	BL25/1	BL25/2
40	85	BL40/1	BL40/2
50	100	BL50/1	BL50/2
80	70	BL80/1/R	BL80/2/R
100	90	BL100/1/R	BL100/2/R
150	115	BL150/1/R	BL150/2/R
200	125	BL200/1/R	BL200/2/R
300	170	BL300/1/R	BL300/2/R

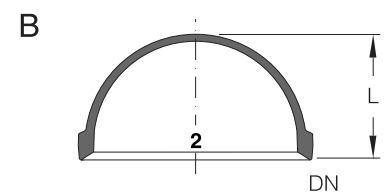
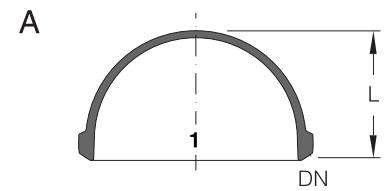

## KF STRAIGHT HOSE CONNECTORS

DN	Schlauch-iØ d	L	Reference
15	8	100	OL15/8
15	20	100	OL15/20
25	8	100	OL25/8
25	15	100	OL25/16
25	20	100	OL25/20
25	30	120	OL25/30
40	50	150	OL40/50
50	60	150	OL50/60

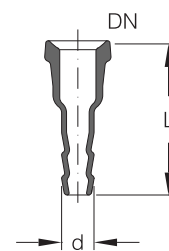

# PIPELINE COMPONENTS

## KF HOSE CONNECTORS, 90°

DN	hose-iØ d	L	L1	Reference
15	20	50	70	OL15/20/W
25	20	100	100	OL25/20/W
25	30	100	100	OL25/30/W

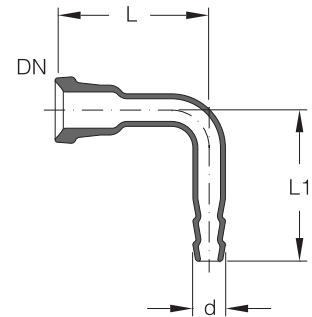

## General

The valves of the KF system, with the exception of pressure retaining valves, vent valves and drain valves, have the same dimensions for connection as the valves in catalogue 6076 but also feature the usual internal parts as found in WPR. The combination of connecting dimensions from the former Schott range with WPR internal parts ensures that valves in existing pipelines can be easily replaced and guarantees quick availability and state-of-the-art technology. Hand-operated valves are fitted with a second seal on the handwheel as standard.



All valves comply with the conditions of the Clean Air Act.

## Permitted operating conditions

The following operating pressure values, related to nominal diameter, apply for a maximum operating temperature of 180°C:

Table 1: **Bellows type valves**

Armatur		Connection DN					
		15	25	40	50	80	100
VEN, VSN, VEN/KP, VEN/SP, VSN/KP, VSN/SP,	$p_S$ (bar g)	3	3	3	2	1,5	-
VEN/RH, VEN/RPK, VEN/RPS, VSN/OL, VEN/LUE, VDN	$p_S$ (bar g)	3	3	3	2	1,5	-
VEN/FS	$p_S$ (bar g)	-	2	-	2	-	2

Table 2: **Return valves, ball-valves**

Armatur		Connection DN					
		15	25	40	50	80	100
KH/G, KHPN/G, KHK, KHKP, VKN/H, VKN/V	$p_S$ (bar g)	4	4	4	4	3	-



Because of the shape of the base and cone, bellow valves with a PTFE cone can be used as both shut-off valves or to roughly regulate flow. The throttle function of these valves is only ensured if the flow is against the cone.



## KF ON/OFF VALVES WITH REGULATING PLUG

### Straight Through Valves

DN	L	H	H1	Reference
15	150	120	90	VSN15
25	200	220	170	VSN25
40	300	285	215	VSN40
50	300	295	225	VSN50
80	400	430	320	VSN80

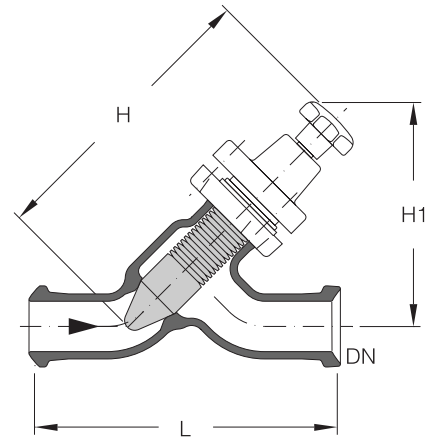

## KF ON/OFF VALVES WITH REGULATING PLUG

### Angle Valves

DN	L	H	Reference
15	50	85	VEN15
25	100	170	VEN25
40	150	215	VEN40
50	150	210	VEN50
80	200	290	VEN80

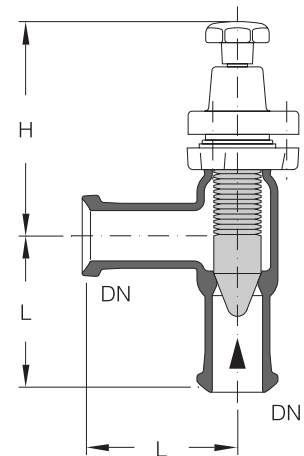

## KF DRAIN VALVES

DN	hose-iØ d	L	H	H1	Reference
15	16	130	120	92	VSN15/OL
25	16	150	120	92	VSN25/OL
50	26	225	223	170	VSN50/OL

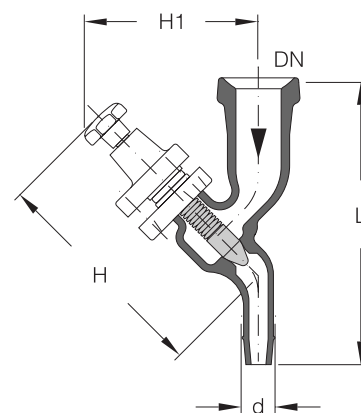

## KF VENT VALVES

DN	hose-iØ d	L	L1	H	Reference
25	16	80	60	85	VEN25/LUE

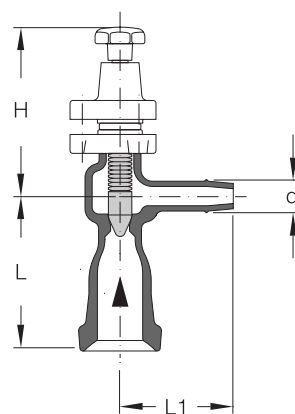

## LOADING VALVES

They are used to provide constant back pressure and are best used behind dosing pumps, but also occasionally behind centrifugal pumps (for which an aperture is generally preferred).

A spring is used in place of the usual manual operation featured with other valves. Its tension setting can be changed using a screwdriver. This makes it possible to set all intermediate values infinitely variably between 0,5 bar g and the permitted operating pressure of the valve, to a tolerance of  $\pm 0,3$  bar.



Please specify pressure setting on the order.

During operation it is important to make sure that the sum of the pressure setting and pressure loss in the valve is not allowed to exceed the maximum operating pressure for the pipeline.

Loading valves must not be used as safety valves as the necessary approval for this type of usage has not been granted.

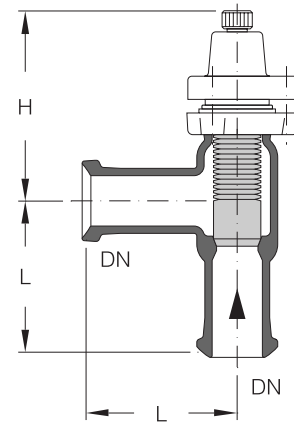

DN	L	H	Reference
15	50	161	VDN15
25	100	155	VDN25
40	150	190	VDN40
50	150	190	VDN50

## KF BALL TYPE NON-RETURN VALVES

The valve is guaranteed to function properly and ensure the correct direction of flow in pipelines in both a horizontal and vertical installed position.

A solid ball is used in vertical pipelines for gasses, vapours and liquids. A hollow ball is used in horizontal pipelines for gasses and vapours. For liquids in horizontal pipelines, it depends on the liquid whether a solid or a hollow ball is used. The product comes into contact with borosilicate glass and PTFE.

These valves can be supplied on request with an O-ring seal in for more extreme impermeability requirements.

However, it is important to make sure that the ball return valve is not used to provide a lasting shut-off effect. The appropriate valves and ball valves, depending on the individual instance of usage, must be used for this purpose.

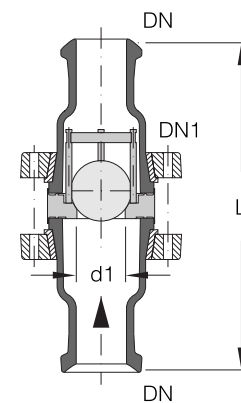

DN	DN1	d1	L	Effektive density (kg/dm <sup>3</sup> )		Reference	
				Hollow ball	Solid ball	Hollow ball	Solid ball
15	50	23	225	0,50	2,2	VKN15/H	VKN15/V
25	50	23	225	0,50	2,2	VKN25/H	VKN25/V
40	80	48	325	0,65	2,2	VKN40/H	VKN40/V
50	80	48	325	0,65	2,2	VKN50/H	VKN50/V
80	80	48	275	0,65	2,2	VKN80/H	VKN80/V

## KF PNEUMATICALLY ACTUATED ON/OFF VALVES

### Angle Valves with Samson Actuator

The pneumatic open/close valve with a Samson drive is actuated with a supply air pressure setting of 2.5 bar g which must not be exceeded by more than 10%. The cone on this valve cannot be used for regulation and is used for reasons of compatibility only.

A "1" must be added to the order number for the position "spring opens" and a "2" must be added for the position "spring closes".

On request, the Samson actuating drives can be delivered with the following added accessories:

- Limit signal transmitter with built-in inductive proximity switches with protection type II 2 G EEx ia IIC T6 for signalling the open/close position.
- 3/2-way solenoid valve with protection type II 2 G EEx ia IIC T6 (24 VDC).

DN	D	d1	L	H	Reference
25	168	27	100	368	VEN25/SP...
40	168	27	150	411	VEN40/SP...
50	168	27	150	409	VEN50/SP...
80	280	27	200	512	VEN80/SP...

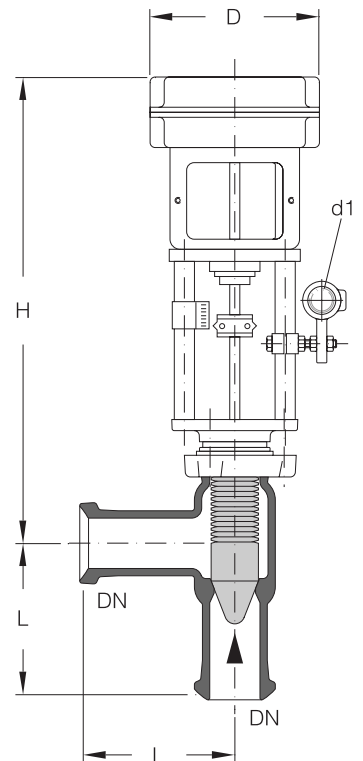

## KF PNEUMATICALLY ACTUATED ON/OFF VALVES

### Angle Valves with Flowserve-Kämmer Actuator

The pneumatic open/close valve with a Flowserve-Kämmer drive is actuated with a supply air pressure setting of 2.5 bar g which must not be exceeded by more than 10%. The cone on this valve cannot be used for regulation and is used for reasons of compatibility only.

A "1" must be added to the order number for the position "spring opens" and a "2" must be added for the position "spring closes".

On request, Flowserve-Kämmer actuating drives can be supplied with the following added accessories:

- Housing with built-in inductive proximity switches with protection type II 2 G EEx ia IIC T6 for signalling the open/close position. Constructed on the drive (the H dimension increases by 80 mm).
- 3/2-way solenoid valve with protection type II 2 G EEx ia IIC T4 (24 VDC).

DN	D	L	H	Reference
25	150	100	215	VEN25/KP...
40	205	150	328	VEN40/KP...
50	205	150	308	VEN50/KP...
80	300	200	409	VEN80/KP...

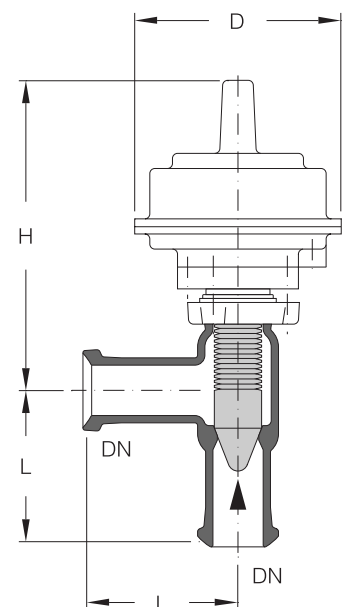

## KF CONTROL VALVES

The regulating performance of the glass control valve is determined by the combination of base and cone. Equal percentage or linear characteristic curves can be selected.

In all cases, the ratio according to VDI / VDE 2173 is 25 : 1.



Three different base diameters are available for nominal diameter DN25.

Valves with a base diameter of 4 or 8 which require a higher level of dosing accuracy, even when exposed to heat, have a cone made of tantalum.

### Available $k_{VS}$ -values

The » $k_{VS}$  value« is a typical figure indicating the flow of water in m<sup>3</sup>/h at 20 °C with a pressure

DN	Sitz-Ø d	Operating characteristic	$k_{VS}$ value m <sup>3</sup> /h															
			0,1	0,16	0,25	0,4	0,63	1,0	1,6	2,5	4,0	6,3	10	16	25	40		
25	4	Equal Percent.	01	03	05	07												
		Linear	02	04	06	08												
25	8	Equal Percent.					09	11	13									
		Linear					10	12	14									
25	16	Equal Percent.								15	17	19						
		Linear								16	18	20						
40	42	Equal Percent.												21	23	25		
		Linear												22	24	26		
50	42	Equal Percent.													23	25	27	
		Linear													24	26	28	

### Catalogue reference key

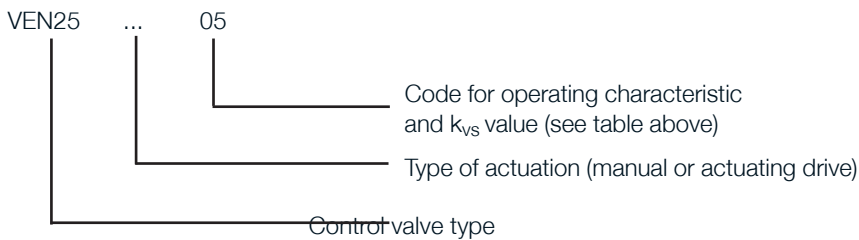

## KF CONTROL VALVES

### Hand Control Valves

DN	L	H	d	Reference
25	100	164	4 / 8 / 16	VEN25/RH/...
40	150	214	42	VEN40/RH/...
50	150	214	42	VEN50/RH/...

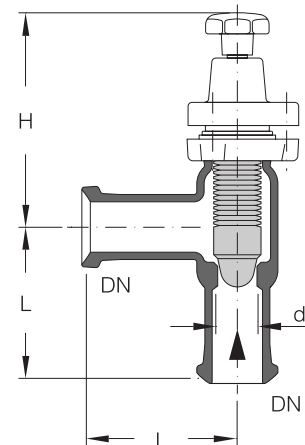

## KF PNEUMATICALLY ACTUATED CONTROL VALVES

These valves consist of the valve body and bellows plug used in our manually operated control valves combined with either a Flowserve-Kammer or Samson diaphragm actuator. Both are fitted as standard with an attached electro-pneumatic I/P positioner of hazardous area type II 2 G EEx ia IIC T6.



The required supply pressure is 2.5 bar g for all actuators and this should not be exceeded by more than 10 %.

When ordering please add the suffixes to the catalogue reference as indicated in the catalogue reference key. The code digit for the required valve flow coefficient (kvs value) and the type of characteristic curve required can be found with the manual-control accoutrements.

### Catalogue reference key

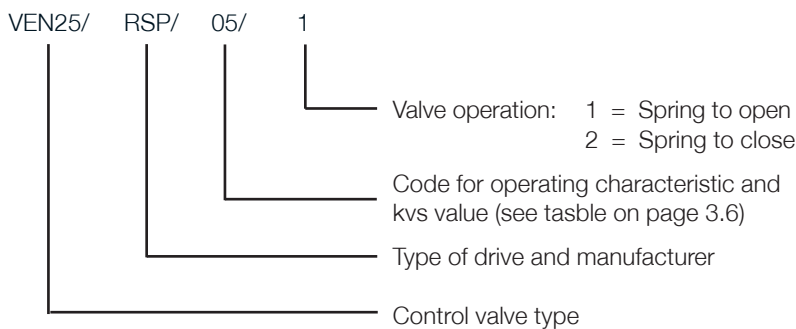

## KF CONTROL VALVES

### with Samson Actuator

If required the positioners fitted to Samson actuators can be supplied with the following additional features:

- Built-in 3 / 2 way solenoid valve, hazardous area type II 2 G EEx ia IIC T6 (24 VDC)
- Built-in inductive proximity switches in accordance, hazardous area type II 2 G EEx ia IIC T6 to indicate if the valve is open or closed.
- Built-in analogue position transmitter, hazardous area type II 2 G EEx ia IIC T6 (4-20 mA). Please note that this can only be supplied in place of the proximity switches detailed above.
- Built-on pressure regulator.

DN	L	H	D2	d	d1	Reference
25	100	370	168	4 / 8 / 16	27	VEN25/RSP/...
40	150	427	168	42	27	VEN40/RSP/...
50	150	427	168	42	27	VEN50/RSP/...

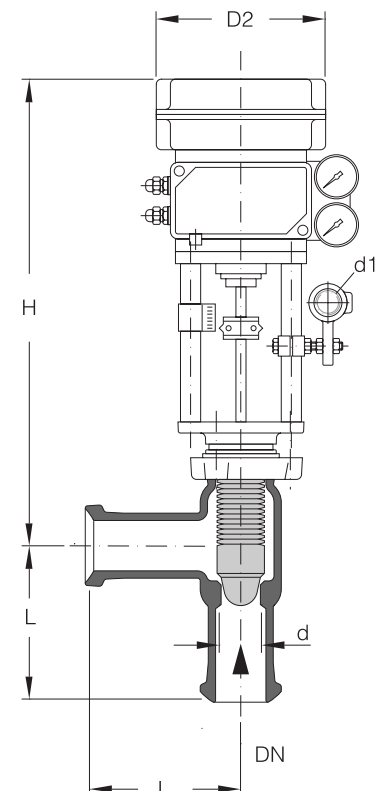

## KF CONTROL VALVES

### with Flowserve-Kämmer Actuator

Flowserve-Kämmer actuators can be supplied with the following additional built-on features on request:

- Inductive proximity switches in accordance, hazardous area type II 2 G EEx ia IIC T6 to indicate if the valve is open or closed. These are fitted into a housing mounted on top of the actuator (Dimension H increases by 80 mm).
- 3/2-way solenoid valve with protection type II 2 G EEx ia IIC T4 (24 VDC).

DN	L	H	D2	d	d1	Bestell-Nr.
25	100	386	150	4 / 8 / 16	27	VEN25/RKP/...
40	150	552	205	42	27	VEN40/RKP/...
50	150	552	205	42	27	VEN50/RKP/...

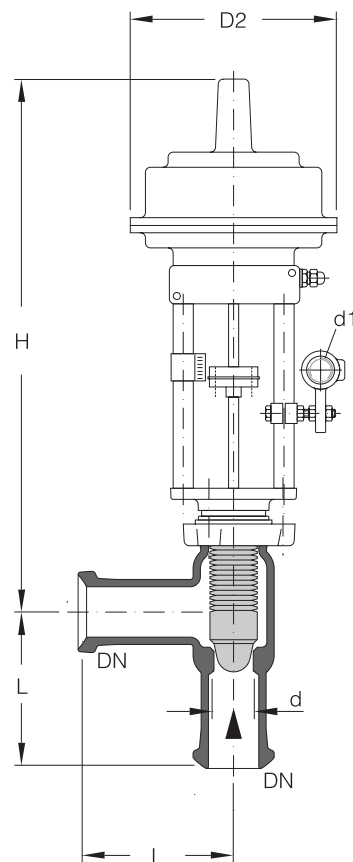

## KF PRESSURE RELIEF VALVES

These valves are officially tested and approved for gases and vapours. They are direct operating and spring-loaded proportional (normal) pressure relief valves with a proven glass/PTFE seat/plug combination and are used to protect plant and equipment against exceeding the stated and/or approved operating pressure in accordance with the actual guidelines for pressure equipment.

The connection dimensions correspond to the valves in catalogue 6076. Flange DN2 is produced as a flat safety flange so that the upper parts are identical to the WPR version.

Before delivery, each valve is durably marked with the component reference »TÜV·SV...590·d<sub>0</sub>·D/G·α<sub>w</sub> p« issued by the notified body. In this reference: ...indicates the year of the applicable test report, 590 the test number, d<sub>0</sub> the smallest flow diameter in mm, D/G the approval for gases and vapours, α<sub>w</sub> the discharge coefficient and p the setting pressure in bar g.



When ordering, please indicate the catalogue reference and the required blow-off pressure in bar g.

The overpressure setting can only be changed by a qualified person (e.g. by QVF). The valve must then be re-loaded and the type plate must be changed.

To ensure that they function properly, pressure relief valves must always be installed vertically. Support fittings are available for this purpose.

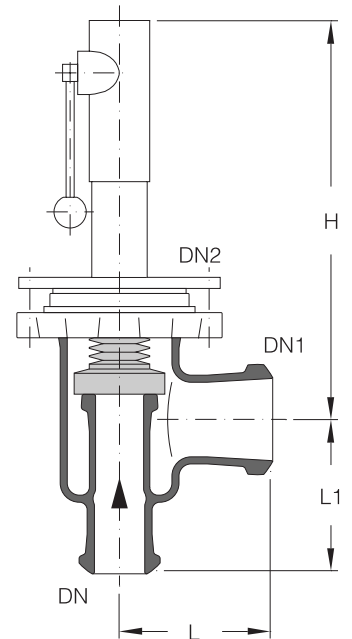

DN	DN1	DN2	L	L1	H	Reference
25	50	80	150	125	325	VEN25/50FS
50	80	100	150	150	395	VEN50/80FS
100	150	150	200	225	480	VEN100/150FS

### Technical Data

DN	Minimum flow diameter d <sub>0</sub>	Minimum flow cross section A <sub>0</sub> (mm <sup>2</sup> )	Discharge coefficient α <sub>w</sub>	Set pressure range p (bar g)
25	25	490	0,44	0,26-1,51
50	50	1960	0,10	0,08-0,25
50	50	1960	0,19	0,18-1,39
100	100	7850	0,17	0,07-1,18

## KF BALL VALVES

### Ball Valves with Borosilicate Glass 3.3 Body

The ball and the shaft is PFA coated. The sealing rings are made of PTFE. The housing and the adapters are made of borosilicate glass 3.3. The selector shaft is sealed by a PTFE coated O-ring and is maintenance-free.



The maximum permissible operating temperature for all versions is 180 °C. The maximum permissible operating pressure is the same in each case as for the corresponding size borosilicate glass 3.3 pipeline.

DN	L	H	H1	Reference
25	200	115	150	<b>KH/G25</b>
40	300	155	225	<b>KH/G40</b>
50	300	160	225	<b>KH/G50</b>

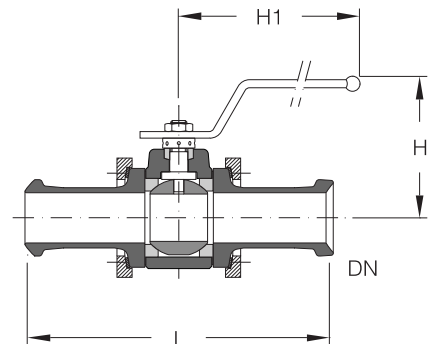

## KF BALL VALVES

### Compact Ball Valves with GGG/PFA Body

The compact ball valves have a characteristic short installed length and are suitable for direct installation in KF pipeline system pipelines due to their double-sided universal connection. They can be installed using SCHD.../K flange rings. The ball and the shaft is PFA coated. The sealing rings are made of PTFE. The selector shaft is sealed by a self-adjusting, maintenance-free gland made of PTFE.



The maximum permissible operating temperature for all versions is 180 °C. The maximum permissible operating pressure is the same in each case as for the corresponding size borosilicate glass 3.3 pipeline.

DN	L	H	H1	E	K x n x d	Reference
25	80	115	150	15	85 x 4 x M8	<b>KHK25</b>
40	100	155	225	16	110 x 4 x M8	<b>KHK40</b>
50	125	160	225	23	125 x 4 x M8	<b>KHK50</b>

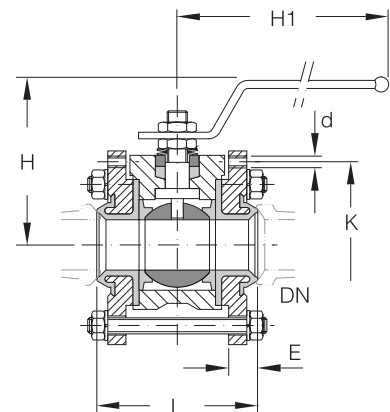

## KF PNEUMATICALLY ACTUATED BALL VALVES

The ball valves can be supplied as standard with single-acting Flowserve-NORBRO drives. Their resettable spring means you have the advantage of being able to choose between the safety positions "spring open" and "spring closes".

Technical data and installation dimensions of these ball valves are the same as for the manually operated version.



Compressed air is required at 5.5 bar g for single-action actuators with the full number of springs.

To avoid the sudden build-up of high surface pressure between the ball and operating spindle at the start of the opening or shutting action, we recommend the incorporation of air flow controls in the supply line to the actuator.

When ordering please add a »1« to the catalogue reference if the »spring-to-open« fail-safe version is required or a »2« for »spring-to-close«.

The »spring to open« setting can be changed to »spring to close« and vice-versa by changing the position of the operating spindle in the actuator by 90°.

If required, two inductive proximity detectors of hazardous area type EEx ia IIC T6 to indicate on/off can be supplied for the actuators.

## KF PNEUMATICALLY ACTUATED BALL VALVES

### Ball Valves with Borosilicate Glass 3.3 Body

DN	L	H	H1	Reference
25	200	182	155	KHPN/G25
40	300	240	195	KHPN/G40
50	300	244	195	KHPN/G50

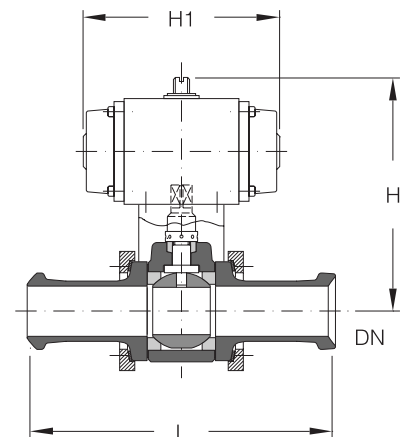

## KF PNEUMATICALLY ACTUATED BALL VALVES

Compact Ball Valves with GGG/PFA Body

DN	L	H	H1	E	K x n x d	Reference
25	80	208	155	15	85 x 4 x M8	<b>KHKP25</b>
40	100	255	195	16	110 x 4 x M8	<b>KHKP40</b>
50	125	259	195	23	125 x 4 x M8	<b>KHKP50</b>

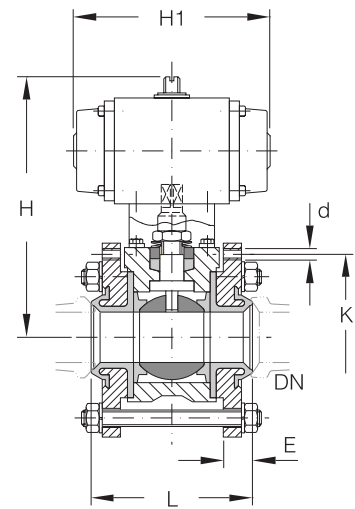

## KF COUPLINGS

### General

An important factor for ensuring operational safety and keeping the requirement for maintenance for glass installations as low as possible is the right choice of flange rings and seals.

The scope of delivery for a flange coupling includes two flange rings and two inserts in the selected material as well as screws, nuts, washers and stainless steel springs. The gaskets are not included in the scope of delivery and must be ordered separately.

The use of springs ensures that the screw force is set properly and at the same time makes sure it is maintained once the seal has settled. Take the value for maximum tightening torque from the following table. Stainless steel screws must be greased during installation to prevent the screws from blocking. The values shown below refer to greased screws.

Nominal size DN	Maximum tightening torque for screws (Nm)	Compressed length of spring (mm)
15	0,8	11
25	1,2	14,5
40	1,2	14,5
50	1,2	14,5
80	1,2	14,5
100	1,2	14,5
150	2,8	24,5
200	2,8	24,5
300	2,8	24,5

The same couplings can be used for coated glass components. The centring pins on the plastic inserts must only be removed for nominal diameters DN 200 and DN 300.

The listed order numbers correspond to those from catalogue 6076 whereby stainless steel screws are always used with springs.



Couplings with long screws are used to install spacers. The length of the spacer must be added to order number for the coupling, e.g.: SVED25/K/25.

## KF COUPLINGS

### Couplings with Plastic Flanges

These are the couplings which are used most frequently as they are both light-weight and highly resistant to corrosion. No other measures against electrostatic charges are required in areas at risk from explosion. The flange rings and inserts are made of fibreglass reinforced duroplastic. Whereas the inserts are hinged, the flange rings are a one-piece construction. With the exception of nominal diameter DN 15, they all have a pitch circle and number of bores as per EN1092, PN10 but smaller screw diameters.



The plastic flange coupling is suitable for a product operating temperature of 200°C but may only be insulated up to a product operating temperature of 150°C.

DN	D	K	n x d1	H	Type	Reference
15	64	50	3 x M6	44	A	SVER15/K
25	105	85	4 x M8	51	A	SVED25/K
40	132	110	4 x M8	65	A	SVED40/K
50	147	125	4 x M8	69	A	SVED50/K
80	184	160	8 x M8	92	A	SVED80/K
100	204	180	8 x M8	93	A	SVED100/K
150	266	240	8 x M8	98	A	SVED150/K
200	321	295	8 x M8	112	B	CP200
300	428	400	12 x M8	113	B	CP300

A

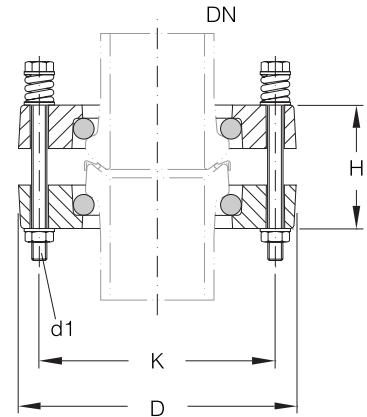

B

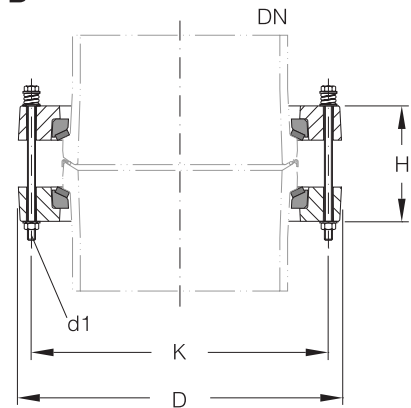

## KF COUPLINGS

### Couplings with Silumin Flanges

Silumin is a metallic material which must be earthed if there is a risk of electrostatic charges in the explosion-risk area, but can resist even higher temperatures. Thus, couplings with silumin clamp rings can be integrated into insulation for a product temperature of up to 200°C.

Standard duroplastic inserts with hinges are used for a nominal width of up to DN 100. Divided silumin inserts with a rubber/fibreglass coating are used for a nominal diameter of DN 150 and above.

DN	D	K	n x d1	H	Type	Reference
15	64	50	3 x M6	44	A	SVER15/S
25	92	75	3 x M8	51	A	SVER25/S
40	118	100	3 x M8	65	A	SVER40/S
50	131	110	3 x M8	69	A	SVER50/S
80	172	150	6 x M8	92	A	SVER80/S
100	192	170	6 x M8	93	A	SVER100/S
150	247	225	8 x M8	100	B	SVER150/S
200	307	280	8 x M8	103	B	SVER200/S
300	429	395	12 x M8	107	B	SVER300/S

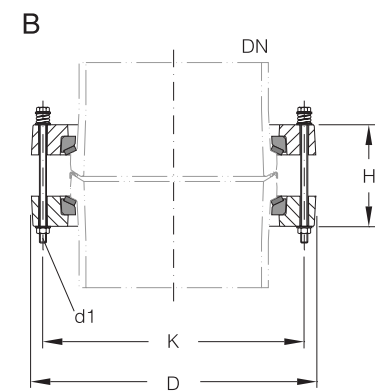
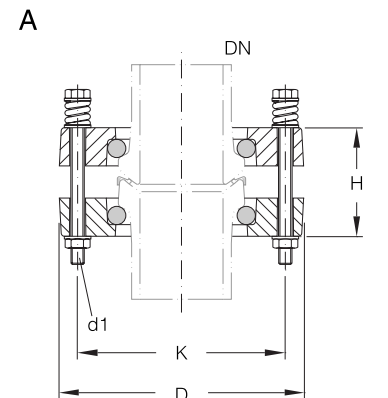

## KF COUPLINGS

### Couplings with silumin flange rings and steel spiral inserts.

When operating acidic products, glass systems may become contaminated by product from outside, e.g. mineral acids. In these cases, the silumin flange is used with stainless steel spiral inserts instead of the duroplast inserts. It is always used in conjunction with an NBR/Aramid base. This coupling can be insulated at up to a temperature of 200°C.

One exception is hydrochloric acid which can corrode stainless steel and silumin, so in this case the standard plastic coupling is preferred as it is resistant to hydrochloric acid. If the flanges of an hydrochloric acid system are to be insulated at higher temperatures, we recommend the use of epoxide resin-coated silumin flange rings with plastic or silumin inserts.



If couplings with epoxide resin-coated flange rings are required, the letter "S" for the material "silumin" must be suffixed with an "E", e.g. SVER25/SE or SVER25/SE/H.

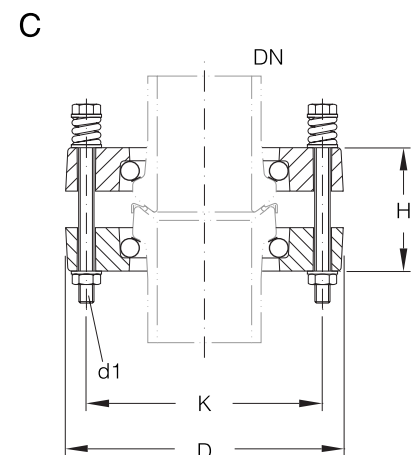

DN	D	K	n x d1	H	Type	Reference
15	64	50	3 x M6	46	C	SVER15/S/H
25	92	75	3 x M8	53	C	SVER25/S/H
40	118	100	3 x M8	67	C	SVER40/S/H
50	131	110	3 x M8	71	C	SVER50/S/H
80	172	150	6 x M8	94	C	SVER80/S/H
100	192	170	6 x M8	95	C	SVER100/S/H
150	For acid systems, use SVER150/S.					
200	For acid systems, use SVER200/S.					
300	For acid systems, use SVER300/S.					

## KF BACKING FLANGES

### Plastic Backing Flanges

Flange rings made of fibreglass reinforced duroplastic with a pitch circle and number of bores as per EN1092, PN 10, except DN 15.

Screw diameters in glass couplings do not correspond to EN dimensions. To connect EN flanges, reducing washers and the respective springs must be used. The length of the screw is determined by thickness of the EN flange.

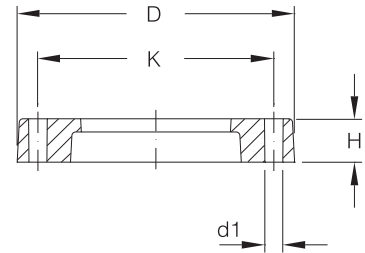

DN	D	K	n x d1	H	Reference
15	64	50	3 x 7,0	14	SCHE15/K
25	105	85	4 x 9,5	17	SCHD25/K
40	132	110	4 x 9,5	20	SCHD40/K
50	147	125	4 x 9,5	23	SCHD50/K
80	184	160	8 x 9,5	28	SCHD80/K
100	204	180	8 x 9,5	28	SCHD100/K
150	266	240	8 x 9,5	34	SCHD150/K
200	321	295	8 x 9,5	34	CRP200
300	428	400	12 x 9,5	36	CRP300

## KF BACKING FLANGES

### Silumin Backing Flanges

Silumin flange rings are not coated as standard.

DN	D	K	n x d1	H	Type	Reference
15	64	50	3 x 7,0	12	A	SCHE15/S
25	92	75	3 x 9,5	14	A	SCHE25/S
40	118	100	3 x 9,5	18	A	SCHE40/S
50	131	110	3 x 9,5	18	A	SCHE50/S
80	172	150	6 x 9,5	24	A	SCHE80/S
100	192	170	6 x 9,5	24	A	SCHE100/S
150	247	225	8 x 9,5	24	B	SCHE150/S
200	307	280	8 x 9,5	26	B	SCHE200/S
300	429	395	12 x 9,5	26	B	SCHE300/S



If epoxide resin-coated flange rings are required, the order number needs to be suffixed with an "E", e.g.: SCHE25/SE.

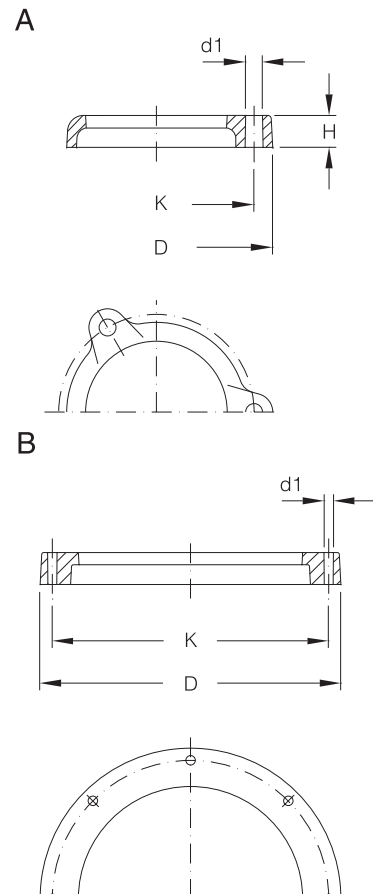

## KF INSERTS

### Plastic Inserts

These inserts can be used in the plastic flange rings up to DN 150 but can only be used in siluim flange rings for up to DN 100. The inserts are divided and hinged.

They can also be used for coated components but if doing so, the centring pins have to be removed for nominal diameters DN 200 and DN 300.

DN	D	H	Type	Reference
15	38	6,5	A	BEIL15/K
25	54	8,0	A	BEIL25/K
40	75	11	A	BEIL40/K
50	89	11	A	BEIL50/K
80	125	14	A	BEIL80/K
100	147	14	A	BEIL100/K
150	200	15	A	BEIL150/K
200	254	18	B	CIP200A
300	359	18	B	CIP300A

A

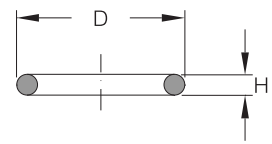

B

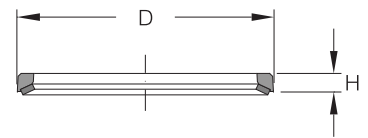

## KF INSERTS

### Stainless steel spiral inserts

Single-piece stainless steel spiral inserts are used if there is a risk of contamination from mineral acids (other than hydrochloric acid). They are always used together with an NBR/Aramid "UNLA" base in silumin flange rings.

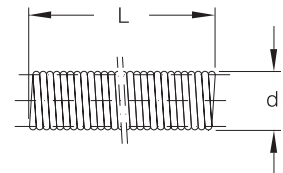

DN	D	L	Reference	Reference
15	6,5	83	BEIL15/S +	UNLA15
25	8,5	123	BEIL25/S +	UNLA25
40	11	170	BEIL40/S +	UNLA40
50	11	215	BEIL50/S +	UNLA50
80	15,5	305	BEIL80/S +	UNLA80
100	15,5	373	BEIL100/S +	UNLA100

## KF INSERTS

### Silumin inserts with rubber/fibreglass layer

This inserts are used with Silumin flange-rings.

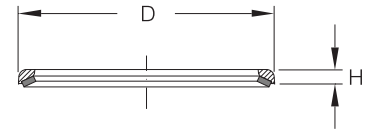

DN	D	H	Reference
150	201	14	BEIL150/AS
200	253	14	BEIL200/AS
300	353	14	BEIL300/AS

## COMPRESSION SPRINGS

Compression springs are used to set the correct bolt load and to maintain it after the gasket has settled, thus ensuring that the coupling remains leak-free. These springs are supplied exclusively in stainless steel.

To achieve the required sealing load and to ensure that the coupling bolts are tightened evenly, first make the nuts finger-tight and then finish off with a spanner (from DN 80 upwards alternating between bolts on opposite sides of the coupling). The free length  $L_0$  and compressed length  $L_1$  are shown in the table on page 9.1. The coupling can also be tightened with a greased screw in line with the torque values already specified.

In the table below »DN« refers to the nominal size of the coupling.

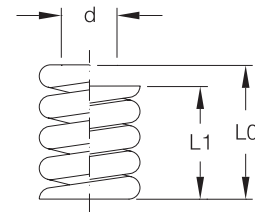

Suitable for coupling DN	d	L0	L1	Reference
15	6,5	13,5	11	DFSS6.5
25	8,5	20	14,5	DFSS8.5
40	8,5	20	14,5	DFSS8.5
50	8,5	20	14,5	DFSS8.5
80	8,5	20	14,5	DFSS8.5
100	8,5	20	14,5	DFSS8.5
150	10,5	30	24,5	DFSS10.5
200	10,5	30	24,5	DFSS10.5
300	10,5	30	24,5	DFSS10.5

## REDUCING WASHERS

When switching over from other materials to the KF series, the usual screw diameters have to be reduced to the screw diameters commonly used in glass couplings using stainless steel reducing washers in order to limit force.

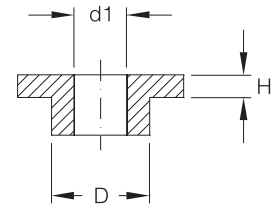

### Reducing Washers for Flanges to EN 1092, PN10

Suitable for KF coupling DN	D	d1	H	Reference
15	13	7	3	RWSS13/7
25	13	9	3	RWSS13/9
40-100	17	9	3	RWSS17/9
150-300	21	9	3	RWSS21/9

### Reducing Washers for Flanges to ANSI, Class 150

Suitable for KF coupling DN	D	d1	H	Reference
15	15	7	3	RWSS15/7
25-40	15	9	3	RWSS15/9
50-100	18	9	3	RWSS18/9
150-200	21	9	3	RWSS21/9
300	24	9	3	RWSS24/9

## GASKETS

### PTFE 'O' Ring Gaskets

'O'ring gaskets are manufactured using a specially selected high-quality virgin PTFE material. If these seals are used, the glass coupling of the KF system is compliant with the requirements of a high-quality coupling as defined by the Clean Air Act.

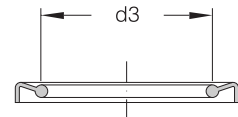

DN	d3	Reference
15	23	DICH15/TG
25	34	DICH25/TG
40	51	DICH40/TG
50	63	DICH50/TG
80	96	DICH80/TG
100	116	DICH100/TG
150	169	DICH150/TG
200	220	DICH200/TG
300	321	DICH300/TG

## KF BELLOWS

### Permissible Operating Conditions for FALD.../UF.. Bellows

PTFE bellows are used in order to accommodate temperature related changes in length and to prevent external forces or oscillations from being transferred onto glass systems.

The bellows are delivered with locking screws to limit their length for installation and recoil force. They are set as of the provided use. The connecting elements are not included in the scope of delivery. Therefore, you must use an FVED... adapter to make the connection to the KF pipe end (e.g. FVED50/UF/K).



The KF-bellows, except DN 200 and DN 300, cannot be used in combination with the safety flat buttress end.

For the permitted operating conditions of PTFE bellows, see the following table:

DN	Pressure corr. Glass DN	Vacuum	unpressurised
15-150	120°C	150°C	200°C
200-300	120°C	120°C	200°C

## KF BELLOWS

Bellows for double-sided connection to glass pipe ends and EN connections as per EN 1902, PN 10

DN	L ± ΔL	D	K	n x d1	d3	E	Reference
15	75 + 4 / -5	95	50	3 x 7,0	23	21	FALD15/UF
25	75 + 4 / -5	115	85	4 x 9,5	35	24	FALD25/UF
40	100 ± 5	150	110	4 x 9,5	53	28	FALD40/UF
50	100 ± 5	165	125	4 x 9,5	64	30	FALD50/UF
80	100 ± 5	200	160	8 x 9,5	96	34	FALD80/UF
100	100 ± 5	220	180	8 x 9,5	116	34	FALD100/UF
150	125 ± 5	340	240	8 x 9,5	169	38	FALD150/UF
200	100 + 3 / -5	390	295	8 x 9,5	220	32	FALD200/UF
300	100 + 3 / -5	460	400	12 x 9,5	321	32	FALD300/UF

When connecting KF pipelines, you require an adapter for each connection, but no additional seals.

When connection EN flanges, reducing washers and the respective springs are used. The length of the screw is determined by thickness of the EN flange.

For connecting flanges with another sealing diameter, an additional DICHN.../TE spacer plate is used.

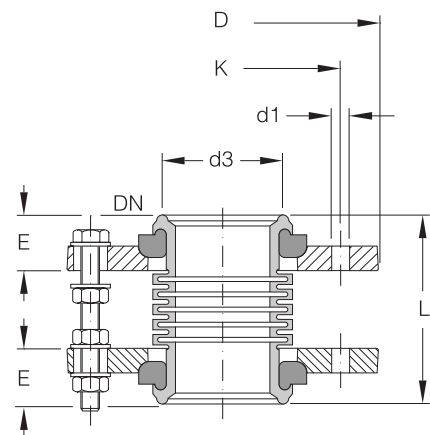

## KF BELLOWS

### Bellows for Connecting Glass and ANSI, Class 150

The pitch circle and the number of holes is in line with the ANSI standard. Use RWSS... reducing washers and the appropriate screws for the nominal diameter in order to centre the reduced screw diameter. The flange thickness determines the length of the screw.

For connecting flanges with another sealing diameter, an additional DICHN.../TE spacer plate is used.

DN	L ± ΔL	D	K	K1	n x d1	n x d2	d3	E	Reference
15	75 + 4/-5	95	50	60	3 x 7,0	4 x 7,0	23	21	FALDA15/UF
25	75 + 4/-5	115	85	79	4 x 9,5	4 x 9,5	35	24	FALDA25/UF
40	100 ± 5	150	110	98	4 x 9,5	4 x 9,5	53	28	FALDA40/UF
50	100 ± 5	165	125	121	4 x 9,5	4 x 9,5	64	30	FALDA50/UF
80	100 ± 5	200	160	152	8 x 9,5	4 x 9,5	96	34	FALDA80/UF
100	100 ± 5	220	180	190	8 x 9,5	8 x 9,5	116	34	FALDA100/UF
150	125 ± 5	340	240	241	8 x 9,5	8 x 9,5	169	38	FALDA150/UF
200	100 + 3/-5	390	295	298	8 x 9,5	8 x 9,5	220	32	FALDA200/UF
300	100 + 3/-5	460	400	432	12 x 9,5	12 x 9,5	321	32	FALDA300/UF

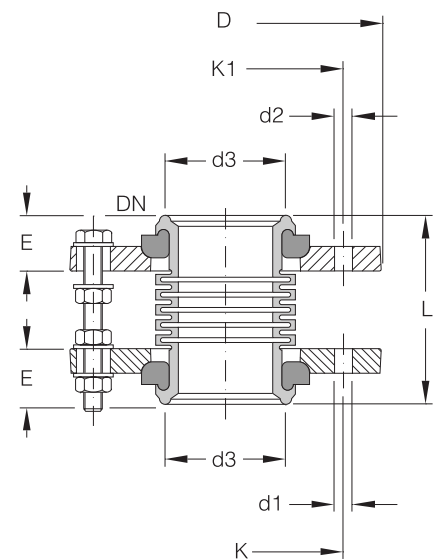

## ADAPTERS FOR CONNECTING GLASS

DN	Reference
15	FVER15/UF/K
25	FVED25/UF/K
40	FVED40/UF/K
50	FVED50/UF/K
80	FVED80/UF/K
100	FVED100/UF/K
150	FVED150/UF/K
200	FVED200/UF/K
300	FVED300/UF/K

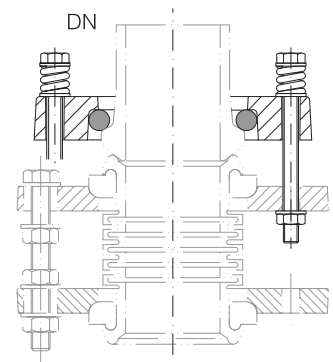

# COUPLINGS

## METAL/PTFE SPACERS

The spacer plate is used if the sealing diameter of the bellows does not come into contact with the sealing surface of the opposite flange. This is the case with enamel connections, for instance.

The spacer plate consists of a PTFE cover and a stainless steel core with an additional soft layer. The spacer of all diameters do have a earthing clip.

DN	DN1	D	d1	d4	L	Reference
25	25	68	25	51	8	DICHN25/TE
40	32	78	32	63	8	DICHN32/TE
40	40	86	40	67	8	DICHN40/TE
50	50	102	50	86	8	DICHN50/TE
80	65	122	65	95	10	DICHN65/TE
80	80	138	80	111	10	DICHN80/TE
100	100	158	100	140	10	DICHN100/TE
150	150	212	150	194	10	DICHN150/TE
200	200	268	200	246	12	DICHN200/TE
300	300	370	300	345	11	DICHN300/TE

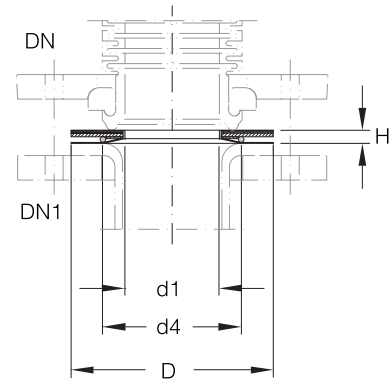

## KF PRODUCT HOSES

The PTFE spiral hoses are shrunk onto borosilicate glass 3.3. adapters with a socket flange on both sides and fastened by a stainless steel clamp.



All spiral hoses are vacuum-proof and can be used at pressure of down to 1 mbar, at an operating temperature of 180°C. You can take the permitted temperature-related operating pressure values from the following table.

DN	d	L	Minimum bend radius	Permissible operating pressure (bar g)			Reference
				20 °C	100 °C	120 °C	
15	10	500	50	4	0,5	unpressurised	WELN15/500
15	10	1000	50	4	0,5		WELN15/1000
25	20	500	85	4	0,5	unpressurised	WELN25/500
25	20	1000	85	4	0,5		WELN25/1000

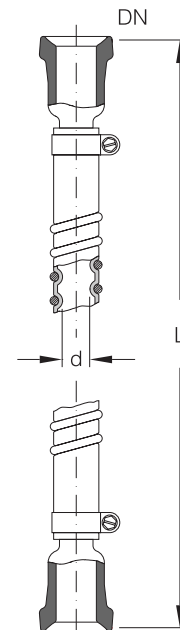

## ADAPTORS KF TO WPR

To connect to safety flat buttress ends a special coupling was developed, with the reference no. CPKFA.... and can be used for ball and socket glass-ends. Following parts are in the scope of supply:

- 2 x SCHD.../K (KF-backing flanges)
- 1 x BEIL.../K (KF-insert)
- 1 x KFA...(adaptor)
- 1 x KRT..., or KRTN... (adaptor PTFE/gasket,  $T_{max} = 130^{\circ}C$ )

screws and springs

For the assembling of DN 80 take care the adaptor gasket KRT is exactly positioned.

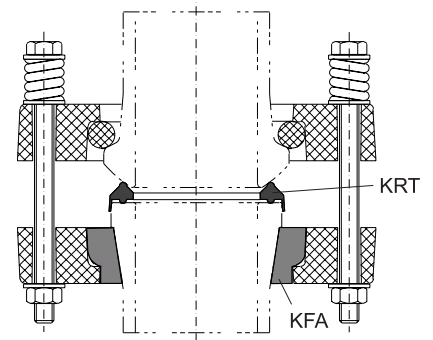

DN	Reference
15	CPKFA15
25	CPKFA25
40	CPKFA40
50	CPKFA50
80	CPKFA80
100	CPKFA100
150	CPKFA150

## SUPPORT BRACKETS

Support brackets are provided for fastening components with a nominal diameter of DN 15 to DN 200 in conjunction with open or closed KK fittings.

Two screws from each coupling are used for DN 15 to DN 50.

The support brackets listed in the following for these nominal diameters are suitable for fastening both plastic flange rings (as per EN1092) and silumin flange rings.

For DN 100 to DN 200, three M8 threaded rods each are used to install the coupling with the pipe sleeves which are welded on. Different support forks are required for the various pitch circles of the flange rings.

The support brackets can be adjusted to the required length on site. The pipe is then closed using the pipe sealing cap which is included in the scope of delivery.

### Universal support bracket for EN/ANSI and silumin pitch circles

DN	L <sup>1)</sup>	L1 <sup>1)</sup>	d	d1	E	Type	Reference Galvanised	Reference Stainless steel
15	-	695	-	7	30	A	GEKAN15/25	GEKAN15/25/E
25	703	703	9,5	-	30	A	GEKAN15/25	GEKAN15/25/E
40	725	717	9,5	9,5	30	A	GEKAN40/50	GEKAN40/50/E
50	738	728	9,5	9,5	30	A	GEKAN40/50	GEKAN40/50/E

<sup>1)</sup>When combining EN1092, PN10 flange ring connections, dimension L applies. For other, dimension L1 applies.

### Support bracket for EN1092, PN10 flange connections

DN	L	K	d	E	Type	Reference Galvanised	Reference Stainless steel
80	695	160	10	22	B	GEKAN80	GEKAN80/E
100	705	180	10	22	B	GEKAN100	GEKAN100/E
150	735	240	10	22	B	GEKAN150	GEKAN150/E
200	Use support bracket HK200... from WPR						

### Support bracket for flange connections with silumin flange rings

DN	L	K	d	E	Type	Reference Galvanised	Reference Stainless steel
80	690	150	10	22	B	GEKAN80	GEKAN80/E
100	700	170	10	22	B	GEKAN100	GEKAN100/E
150	728	225	10	22	B	GEKAN150	GEKAN150/E
200	760	280	10	22	B	GEKAN 200	GEKAN200/E

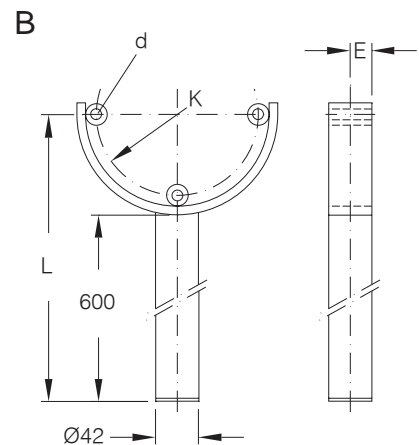
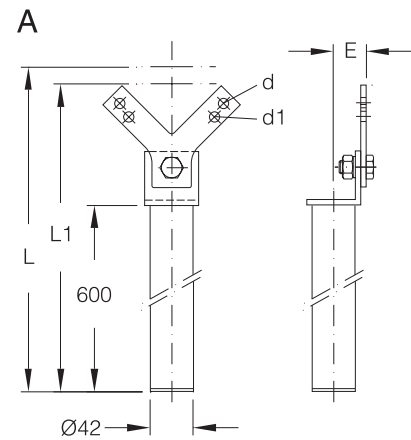

## SUPPORT RING

The weight of glass apparatus and vertical pipelines is transferred onto the support construction by support rings. The support rings have two internal pitch circles; thus they can be used for silumin flanges as well as for plastic flanges. The support rings are fastened to the structure using RRM... pipe frame round nuts on the supporting construction.

For pipelines up to and including DN 100, GEGA... support forks are used in place of support rings.

DN	d1	K	E	E1	Reference Galvanised	Reference Stainless steel
150	14	335	290	84	GETR150/U	GETR150/U/E
200	14	390	338	98	GETR200/U	GETR200/U/E
300	18	520	450	130	GETR300/U	GETR300/U/E

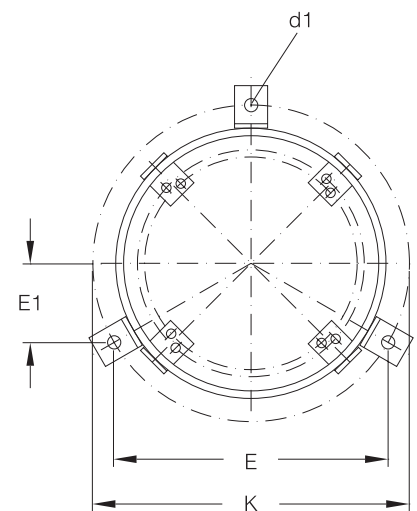

## OUR OFFER TO YOU

### SUPPLIERS OF

Components from Borosilicate glass 3.3 and other corrosion resistant material

- Pipeline Components
- Valves
- Control Instruments
- Heat Exchangers
- Vessels
- Chemical Plant Equipment
- Standard Units

Miniplant Technique for development and production

- Universal reaction units
- Apparatus for Unit Operations
- Process simulation

Standard units for Laboratory and production made from Borosilicate glass 3.3 and other corrosion resistant materials

- Rotary Film Evaporators
- Thin-Film Evaporators
- Crystallizers
- Chemical Plant Reactors

### ENGINEERS FOR

- Feasibility Study
- Basic Engineering
- Detail Engineering
- Procurement
- Commissioning

### PROJECT MANAGEMENT FOR

Engineering, assembling and commissioning of chemical plants made from appropriate material

- Mineral Acid Concentration
- Waste Water Recycling
- Distillation and Rectification with special applications
- Liquid-Liquid-Extraction for recycling of organic substances
- VOC Recovery Units
- Halogenization of organic substances
- Special Processes