

ROTARY EVAPORATOR ROTADEST® R20/R50/R100

P134e.0



GENERAL

Rotary evaporators belonging to the R product range, which are preferred in production and are used in engineering, are suitable for continuous and discontinuous distillation under normal pressure or in a vacuum. They have the advantage of providing careful thermal treatment of temperature-sensitive mediums. Application limits for the rotary evaporator arise among other things as a result of the relatively long dwell time and the attainable viscosity of the final product. Above reliable or attainable limit values, therefore, we recommend the use of our thin-film evaporator which permits a maximum viscosity of the residue of approx. 5000 cP.

Exclusive use of borosilicate 3.3 glass and PTFE for all product-based parts offers the following benefits:

- ☞ Proper observability of all process in the areas of evaporation and condensation.
- ☞ Total chemical resistance against nearly all mediums

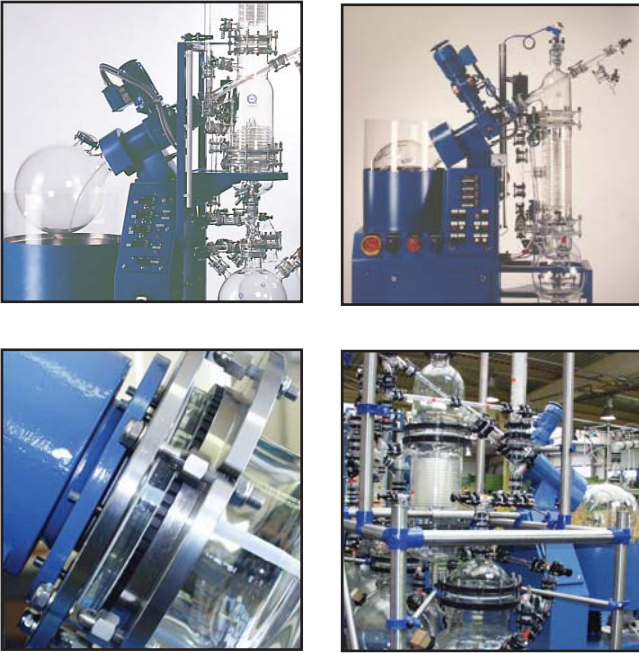

Additional special features of this rotary evaporator are:

- ☞ The robust driving of the rotary sphere by a PTFE-lined steel sleeve shaft and their sealing of the condenser part using a proven PTFE axial face seal (suitable for permanent and maximum load).
- ☞ The possibility of choosing between different housing or bath models, types of heating, condenser parts and different varieties of display and control parts (modular system, see order number key).
- ☞ Simple operation

Rotary evaporators are suitable for evaporating suspensions, initiating crystallisation processes and drying powders and granulates. It is also possible to carry out various chemical reactions.

ORDER NUMBER KEY

	Module A ¹⁾				Module B	Module C	
	Housing with heating bath, rotary sphere and drive				Condenser	Display and control part	
R	100	E	A	H	2	Spezial	Ex
	└─ ROTADEST └─ Content of rotary sphere (20, 50, 100 l) └─ Bath heating (E=electrical, D= steam (Dampf)) └─ Lowerable heating bath (not with R20) └─ Hydraulic or stroke setting				└─ Condenser part (mod. 1 to 3)	└─ Special or standard	└─ Ex - model

¹⁾ housing with wheels are also available

PRINCIPLE OF OPERATION

The liquid to be processed in the rotary evaporator is fed directly into the rotary sphere by a feed pipe conducted through the condenser part. When operating under normal pressure, i.e. with open air release valve, this happens by means of a pump or through gravitational force, depending on the arrangement of the supply vessel.

Evaporation takes place in the externally heated rotary sphere. In this way the rotational movement of the piston ensures a good intermixing of the medium, thus providing regular temperature distribution.

The rotary sphere is indirectly heated by a water or oil bath to which the necessary energy is fed in a regulated way by steam or an electrical heating unit. The steam abandons the sphere at the point where it is flanged to the drive motor. It flows through a sleeve shaft feeding through the drive and reaches the condenser part. There it is condensed in the condenser and cooled in an after cooler. Then the condensate reaches the recipient container(s).

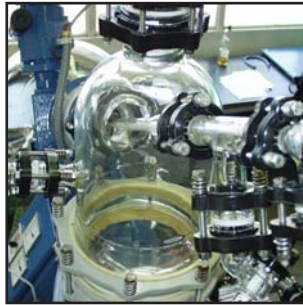

A reversible alternating recipient enables condensate to be withdrawn during operation under normal pressure and in a vacuum. The simple recipient makes this possible only with distillation under atmospheric pressure.

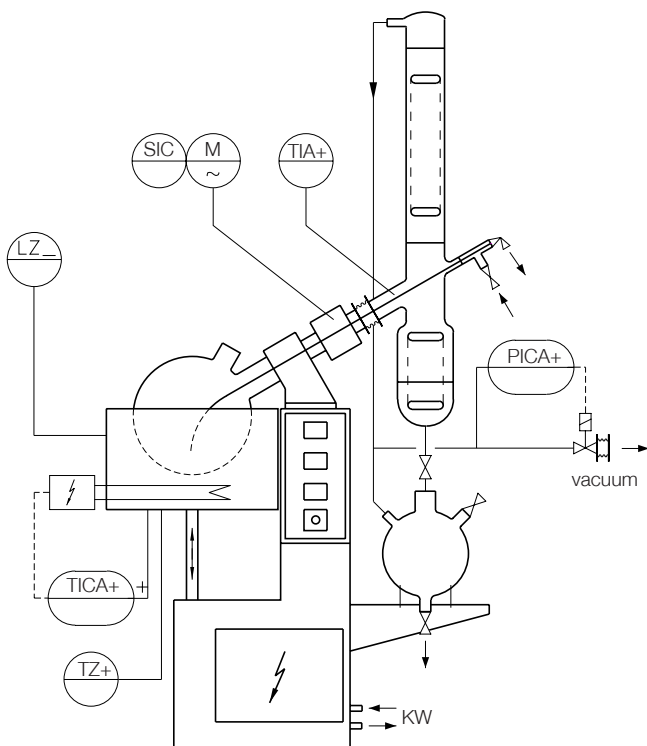

EVAPORATION RATES

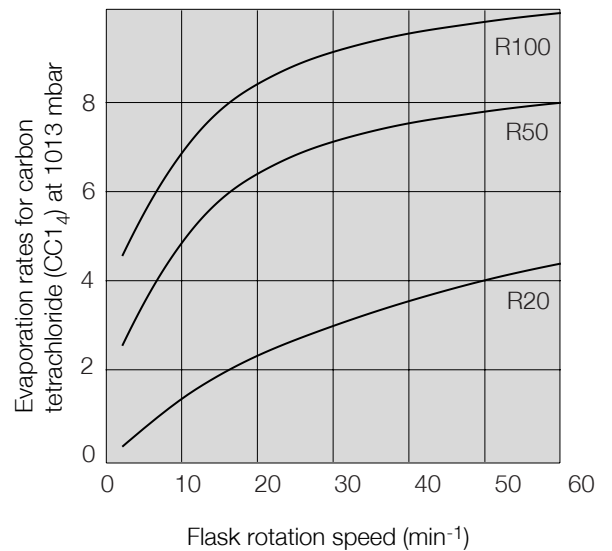
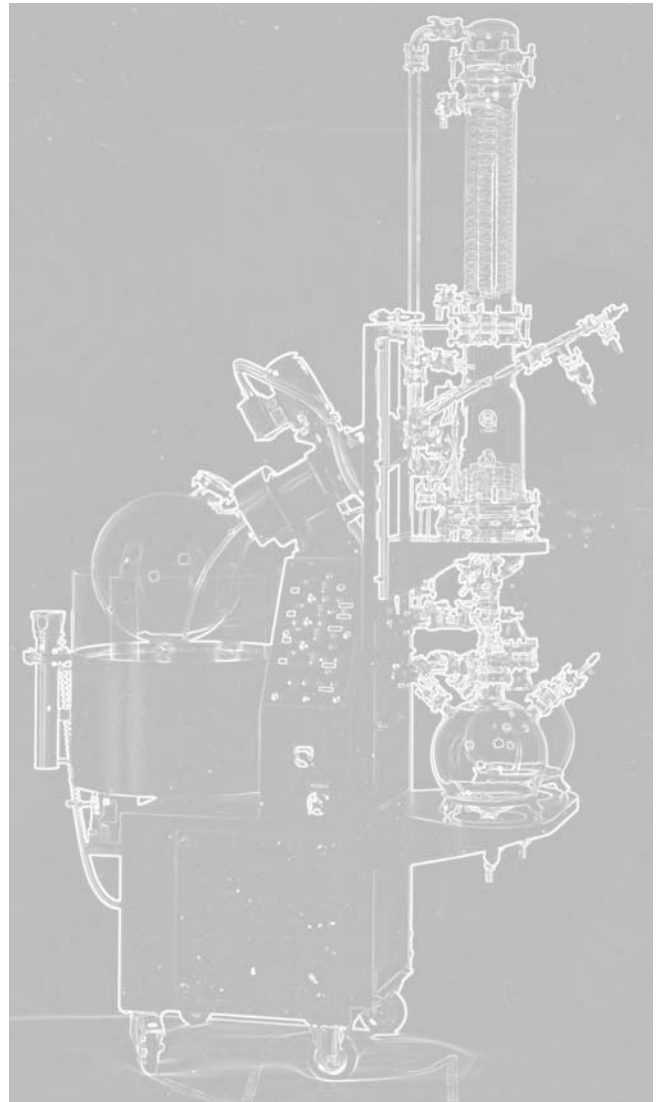

Fig. above: The variation of evaporation rates of carbon tetrachloride with the flask rotation speed.



MODULE A

HOUSING WITH HEATING BATH, ROTARY SPHERE AND DRIVE

Only housing models with integrated heating bath are available for size R20 rotary evaporators. The possibility of lowering the bath heating is not necessary here because the overall height and the content of the sphere are low. To make assembly and disassembly easier the sphere can be equipped with an additional support ring.

Housings for the R50 and R100 rotary evaporators can be delivered with permanently installed or lowerable heating bath. With the model just mentioned the bath heating is raised and lowered using a hydraulic cylinder. The standard version activates it with a hand pump or a pressure outlet valve. The special model on the other hand is delivered with an electrical oil pump and an on/off button on the operator panel. In the event of power failure or network shutdown, in both variants the heating bath is forcibly lowered with a magnetic valve. The entire hydraulic installation including the oil supply container is placed in the housing. All heating baths can be heated either electrically or with steam. Either water or other heat exchangers, e.g. oil, can be used as a bath liquid. A splash guard keeps back the entrained bath liquid with the rotation of the sphere and serves at the same time as protection against accidental contact.



The rotary evaporator's housings are delivered ready for connection i.e. including internal pipework and wiring. The accesses and outlets for the cooling water to and from condenser parts are in the housing wall. The associated manually actuated valve is placed on the operator side. A duct is planned for the electrical connection.

ROTARY SPHERE

In all rotary evaporators this consists of nearly totally corrosion-resistant borosilicate 3.3 glass. Attachment to the drive makes detachment easier using hasp screws. Use of special palettes when assembling and disassembling the spheres also simplifies this job. Such palettes are, however, only usable in housing versions with lowerable heating baths and can be delivered as an accessory.

The nominal capacity of the spheres is 20, 50 or 100 litres. For the purpose of intensive intermixing as well as for powdered substances the rotary spheres can also be delivered with indentations (internally raised) distributed above the surface.



DRIVE

In all models a robust and proven drive motor serves as a power plant for the rotary sphere. Its driving motor speed can be continuously adjusted by hand. Speed measurement with digital display on the operator panel can be provided.

An electric motor with frequency converter, setpoint adjuster and digital display can be provided as an alternative to the drive motor, likewise at extra cost.

A PTFE-lined steel sleeve shaft serving as a vapour pipe, to which the rotary sphere is permanently attached, is directly driven at the same time. This sleeve shaft is sealed against the condenser part by a PTFE axial face seal. The connection of drive and condenser part is made by a PTFE bellows.

All rotating parts, including the connection flange of the rotary sphere are sealed with a protective cap.

TECHNICAL DATA

Type			R20...	R50...	R100...
Rotating flask	Capacity	l	20	50	100
	Rotation speed	min ⁻¹	0 - 108	0 - 82	0 - 82
Drive	Type		Drive motor with continuous speed regulation ¹⁾		
	Power	kW	0,25	0,37	0,37
Bath heating	Electrically heated ²⁾	kW	4,5	9	12
	Steam heated	bar	6	6	6
Bath activity	Hand hydraulics		Hydraulic cylinder, hand pump, pressure outlet valve, automatic lowering during power failure or network shutdown by magnetic valve		
	Motor hydraulics		Hydraulic cylinder, electrical oil pump, on/off button (forced gearing as in standard)		

¹⁾ Alternative motor with electrical speed regulation by frequency converter at extra cost

²⁾ Surface temperature is limited to 160°C, for equipment in Ex-zones to 120°C.

MODULE B

CONDENSER PART

This module is the complete condenser part in which the condensate is condensed and collected. It essentially consists of a condenser with or without an after cooler, one or two recipients, the connecting pipes, including the necessary fixing as well as a vacuum connection. The condenser part is supported by a console attached to the housing.

Condenser parts have already been designed and delivered in a variety of different models to cater to the special desires of the user. However, experience has shown that a wide field of application is covered by the varieties described below. They all have product feeding, concentrate and distillation extraction, connections to cooling water and vacuum as well as a ventilation and pressure measurement connection.

CONDENSER OPTION 1

This condenser arrangement with integral spherical receiver has single vacuum, venting and drain connections fitted with valves. The vacuum connections is equipped with a bellows via tee-piece for connection to both vacuum pump and pressure gauge. There is also a facility for filling and suction emptying the rotating flask. This arrangement is supported by means of a bracket fixed to the cabinet.

Rotary film evaporators incorporating this type of condenser arrangement are suitable for continuous operation at atmospheric pressure or batch operation under vacuum.

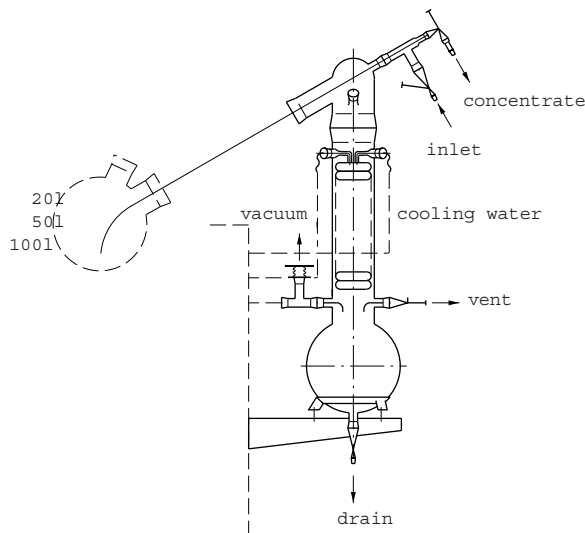

Option 1:

CONDENSER OPTION 2

This version has the same principal as option 1 but utilises a standard condenser. This system is fitted with two spherical receivers, therefore allowing one to be exchanged, enabling continuous operation under vacuum as well as atmospheric pressure. The vacuum connection in this system is fitted with the bellows unit.

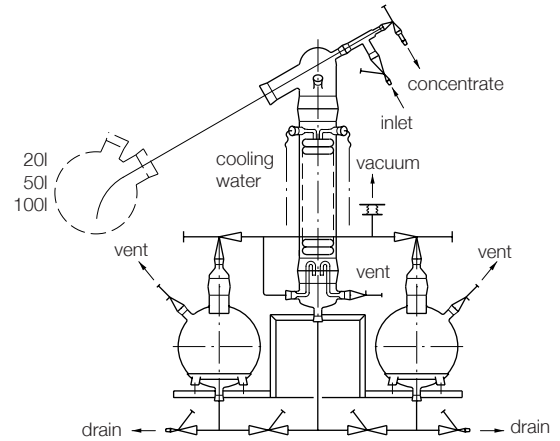

Option 2:

CONDENSER OPTION 3

This system incorporating a combined condense and product cooler was developed for particularly high performance cooling and continuous operation under vacuum. A rising condenser and a flooded secondary product cooler ensure optimum cooling of the condensate. The exchangeable receivers also provided, permit continuous operation under vacuum as well as atmospheric pressure. The flooding of the lower cooler is achieved by means of a overflow.

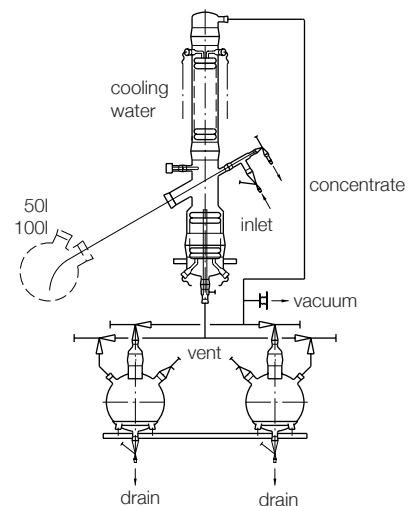

Option 3:

Condenser part			Option 1	Option 2	Option 3
Cooler	R20...	m ²	1,0	1,0	
	R50...	m ²	1,5	1,5	1,5+0,7
	R100...	m ²	2,5	2,5	2,5+0,7
Capacity	R20...	l	10	2x10	
	R50...	l	20	2x20	2x20
	R100...	l	50	2x20	2x20

MODULE C

This module includes all component parts of the rotary evaporator for monitoring and controlling the distillation process parameters. The operating panel with analogue and/or digitally display devices and buttons, positioned for the convenience of the operator, is placed in the upper housing part. The main switch is directly below the operator panel.

All housings with their switch and control gear are, as with the terminal boxes, placed in the lower housing part of the rotary evaporator and easily accessible from outside by a removable cover. Explosion-protected models have compression-proof enclosed housings.

In all other cases they are designed splash-proof (IP 54 type of protection). The operator panels have analogue or digital displays depending on the model (see technical data):

- the head temperature in the condenser
- the bath temperature
- the vacuum
- the speed of the rotary sphere (special request)



Fig. above: glass parts with dissipative coating.

One power supply 230/400 V, 3 Ph, N, PE.

TECHNICAL DATA

Function		Design	Standard Standard Ex	Special Special Ex
Head temperature		Measurement	Thermometer with expansion sensor ¹⁾	Resistance thermometer with electric display ¹⁾
		Display	Analogue	digital
Bath temperature	electrically heatable	Measurement	Thermometer with expansion sensor as two-position controller incl. limit value signal max.	Resistance thermometer with electr. two-position controller incl. limit value signal max
		Display	Analogue	digital
		Control	Two-position controller	Two-position controller
	steam heated	Measurement	Thermometer with expansion sensor incl. max. limit value signal	Resistance thermometer with electr. two-position controller incl. limit value signal max
		Display	Analogue	digital
		Control	direct-acting thermostat with set value area +50 + +150°C	
Vacuum		Measurement	Manometer with measurement range -1 to 0 bar ²⁾	Absolute pressure transmitter with electric indicator ^{2),3)}
		Display	Analogue	digital
RPM		Final control element Display	Handwheel with vernier scale	Handwheel with vernier scale at extra cost (with digital display)

¹⁾ With limit value signalling Max at extra cost

²⁾ With limit value signalling min at extra cost

³⁾ Alternative electrical two-position controller at extra cost.

DIMENSIONS

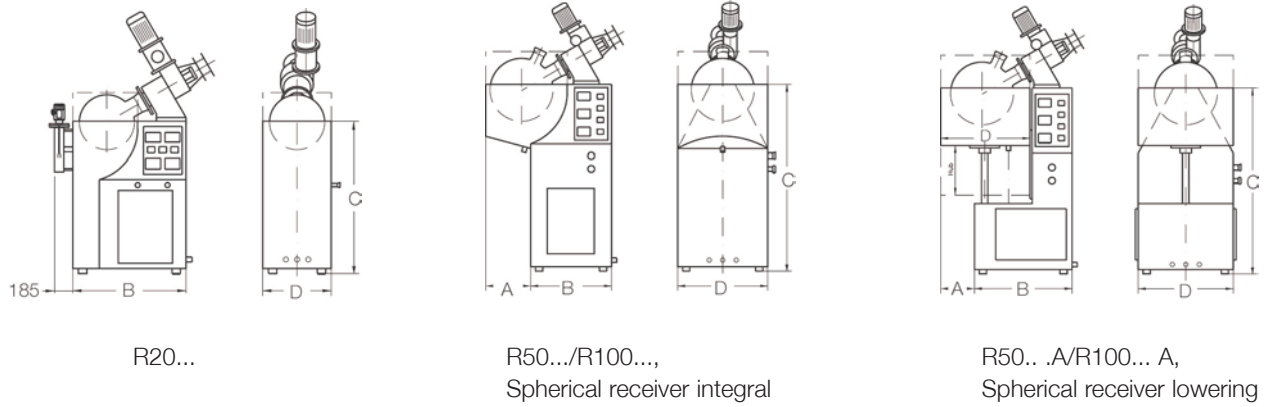

Spherical receiver ¹⁾		integral	lowering	
Type		R20...	R50...A	R100...A
A	mm	0	290/475 ²⁾	340/525 ²⁾
B	mm	760/945 ²⁾	760	810
C	mm	1150	1450	1550
D	mm	660	740	840
Hub	mm	-	320	380

¹⁾ control panel can be installed on the other side

²⁾ inclusive level control (in case of Ex-proof version)

CONDENSER PART

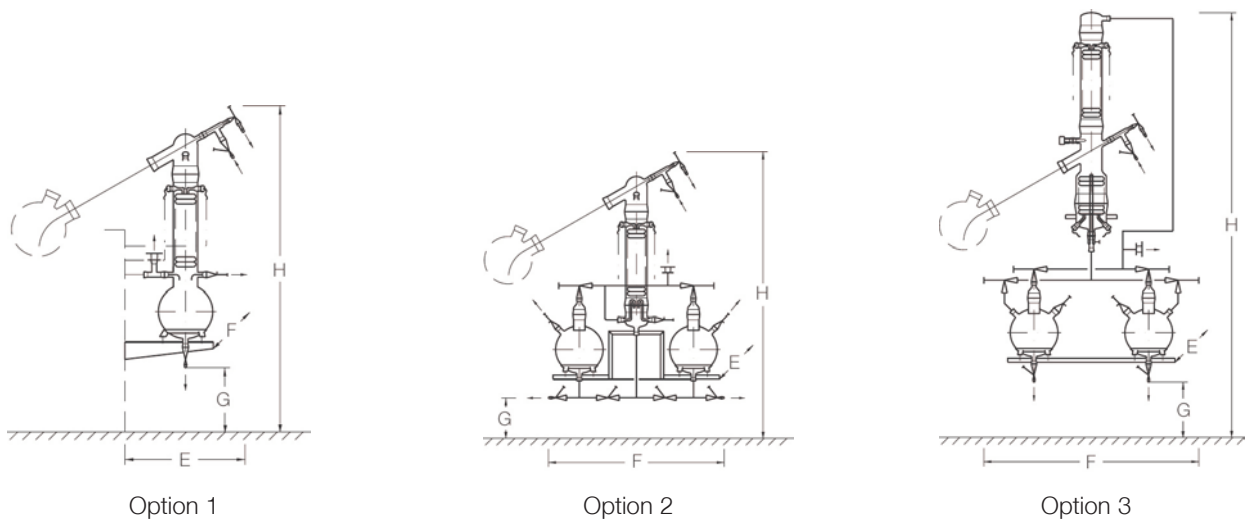

Condenser		Option 1			Option 2			Option 3	
Type		R20...	R50...	R100...	R20...	R50...	R100...	R50...	R100...
E	mm	720	750	815	720	750	815	765	815
F	mm	620	370	610	940	1230	1230	825	825
G	mm	420	530	450	420	530	375	525	510
H	mm	1950	2345	2480	1950	2345	2480	3285	3375

QVF ENGINEERING GMBH

Postfach 33 69
D-55023 Mainz
Hattenbergstraße 36
D-55122 Mainz

Tel.: (+49) 0 61 31/ 97 04-0
Fax: (+49) 0 61 31/ 97 04-500
E-mail: mail@qvf.de
Internet: www.qvf.com

