

REACTION UNITS

Expensive and high-grade products are not produced in large quantities, as they are typical for pharmaceutical industry, and also for fine and special chemical areas. Small, flexible facilities are necessary for these applications, which can be easily cleaned and quickly be adjusted for the next product.

A special requirement is common within the above-mentioned industries; they need corrosion resistant materials that do not interact with the product and do not contaminate it. A further problem is cross-contamination, which must be prevented by ensuring dead space free design by specially developed parts. GMP conform implementation become more and more important, especially for pharmaceutical products.

Development departments and institutes are also interested in flexible-design of reaction because they also operate with small product quantities. In addition, it is frequent that only limited space is available for the assembly of the facility, and therefore compact design is preferred that enables installation in fume cupboards.

STIRRER WITH MAGNETIC DRIVE

The magnetic stirrer guiding of our stirrer is a safe, TA-Luft conform sealing unit with the following features:

- Use of corrosion resistant materials PTFE, PFA, PEEK that are in contact with the product
- This magnetic coupling is made of stainless steel and sealed against the product with PTFE shaft seal
- The inner drive chamber can be protected against corrosion with a nitrogen bleed
- Motor 0.37 kW; 0-600 rpm; 4.1 Nm torque
- Magnetic coupling 7 Nm torque; -1 / +3 bar; 150°C

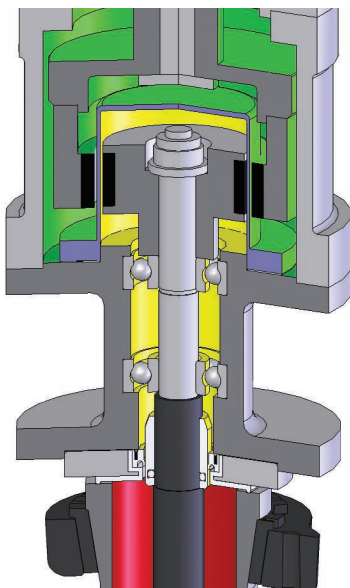

Fig. 2: Design of the magnetic drive

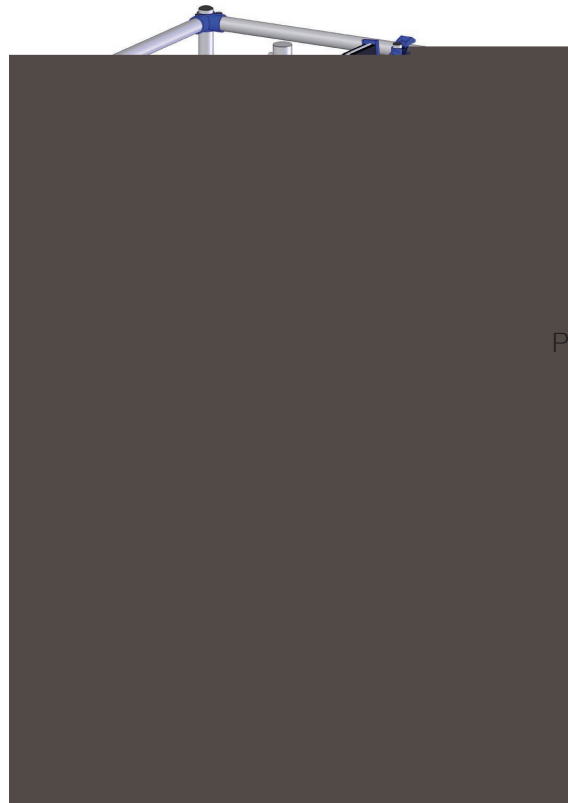

Fig. 1: OptiMix® Reaction unit

P156e.1

GLASS OPTIMIX® AS TRIPLE WALL VESSEL

- Scale-up capability to a glass-lined vessel
- Three baffles are fixed to the inner wall of the reactor, freeing the nozzles of the cover. The baffles are flushed from the rear without dead zones
- Heating and cooling times are halved for the same stirring performance executed
- Mixing times are halved at the same stirring speed
- Available in glass ranging from 6.3 to 25 liters
- The evacuated glass jacket-design around the heating jacket serves as isolation, and prevents the formation of ice at low temperatures; (-80 / +140°C; dT < 50°C)

DEAD SPACE FREE OUTLET VALVE

The new QVF® bottom outlet valve seals the vessel dead space free. As PTFE is getting softer at high temperatures,



Fig. 3: Glass OptiMix®

high-grade connections are equipped with spring elements at QVF®. The new bottom outlet valve implements two sealings of this type. The first sealing is self-adjusting, and almost without a gap between glass body and PTFE bellow at position 1 (Fig.4). The spring at position 2 (Fig. 4) is pre-loaded due to the closing movement of the valve. This way a constant pressure of the PTFE-plug against the valve seat is maintained over a wide temperature range.

The folds of the bellow rounded in order to enable well-cleaning capability. A version with integrated PT 100 and also a torque limitation is available.

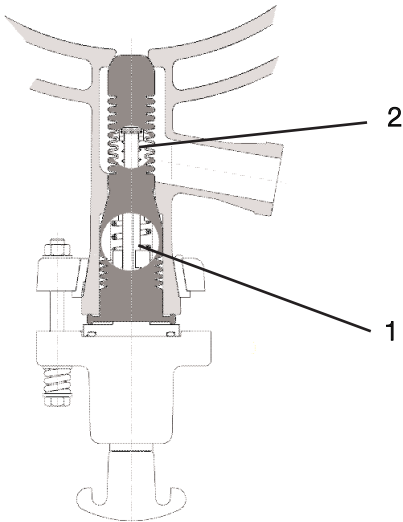

Fig. 4: Bottom Outlet Valve

GMP VERSION

GMP conform design is a basic requirement for multi-purpose facilities:

- The whole construction is dead space free
- All pipelines drain especially due to the 5° slope of the horizontal lines and due to the use of special GMP gaskets
- The vessel can be easily inspected and cleaned due to lowering device.

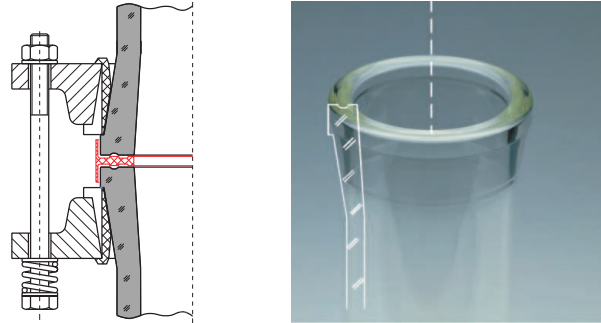

Fig. 5: Safety flat buttress end with GMP gasket

SKID-DESIGN

If possible, DDPS reaction units are assembled at the manufacturer's location, and delivered to the customer upon successful FAT. Our worldwide operating service personnel can provide assembly on-site. Especially the adaptation of the design to fit your requirements makes DDPS reaction units your success.

EXPLOSION PROTECTION FOR ZONE 0/1

- All measuring devices are approved for internal operation in a Zone 0 environment; the stirrer is approved for operation in a Zone 1 environment
- Wireless control may be implemented for a Zone 1 environment
- Dissipative coating in connection with dissipative gaskets is a patented application of QVF®
- Dissipative gaskets and fittings with FDA certification are available



Miniplant

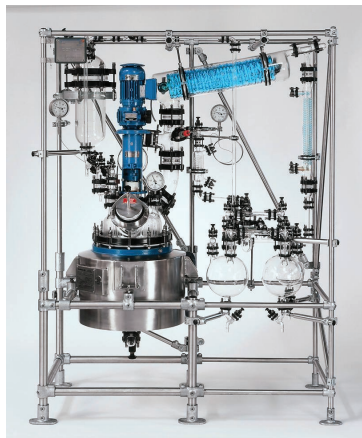

Kilo-Lab

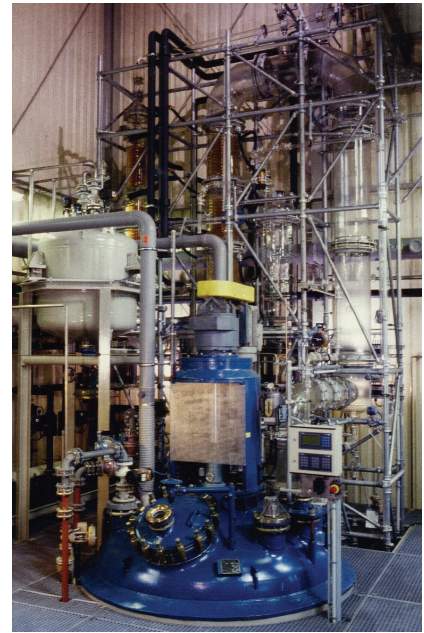

Production

06.09. P156e.1. subject to change. Copyright © 2009, De Dietrich Process Systems GmbH

De Dietrich Process Systems GmbH

Hattenbergstraße 36
D-55122 Mainz
Tel.: +49 (0) 61 31/97 04-0
Fax: +49 (0) 61 31/97 04-500

Geschäftsführer:
Dr.-Ing. J. Korbach
mail@qvf.de
www.qvf.com

USt/VAT-IdNr.:
DE 113 872 810
HRB Nr. 6538
Amtsgericht Mainz

SOCIETE GENERALE / Frankfurt a. M.
IBAN: DE39 5121 0800 0260 1015 47
Kto.Nr.: 260 101 547
BLZ: 512 108 00
SOGÉ DE FF

Dresdner Bank / Wiesbaden
IBAN: DE20 5108 0060 0055 5800 00
Kto.Nr.: 555 800 00
BLZ: 510 800 60
DRES DE FF 510

